

JELD-WEN, inc.

SITELINE OR W-5500 WOOD DOUBLE HUNG MULLION ASSEMBLIES



3737 LAKEPORT BLVD
KLAMATH FALLS, OR 97601
PH: (541) 882-3451 FAX: (541) 850-2609

INSTALLATION NOTES:

- ONE (1) INSTALLATION ANCHOR IS REQUIRED AT EACH ANCHOR LOCATION SHOWN.
- THE NUMBER OF INSTALLATION ANCHORS DEPICTED IS THE MINIMUM NUMBER OF ANCHORS TO BE USED FOR PRODUCT INSTALLATION OF THE MAXIMUM SIZE LISTED.
- INSTALL INDIVIDUAL INSTALLATION ANCHORS WITHIN A TOLERANCE OF ±1/2 INCH (I.E., WITHOUT CONSIDERATION OF TOLERANCES). TOLERANCES ARE NOT CUMULATIVE FROM ONE INSTALLATION ANCHOR TO THE NEXT.
- SHIM AS REQUIRED AT EACH INSTALLATION ANCHOR WITH LOAD BEARING SHIM(S). MAXIMUM ALLOWABLE SHIM STACK TO BE 1/4 INCH. SHIM WHERE SPACE OF 1/16 INCH OR GREATER OCCURS. SHIM(S) SHALL BE CONSTRUCTED OF HIGH DENSITY PLASTIC OR BETTER.
- THROUGH FRAME :** FOR INSTALLATION INTO 2X WOOD FRAMING USE MINIMUM #8 WOOD SCREWS OF SUFFICIENT LENGTH TO ACHIEVE 1 1/2" MINIMUM EMBEDMENT INTO WOOD SUBSTRATE. MINIMUM EDGE DISTANCE OF 3/4" SHALL BE MAINTAINED.
- THROUGH FRAME:** FOR INSTALLATION INTO CONCRETE/MASONRY, USE 3/16" ITW TAPCONS OF SUFFICIENT LENGTH TO ACHIEVE 1 3/4" MINIMUM EMBEDMENT INTO CONCRETE/MASONRY. MINIMUM EDGE DISTANCE OF 2 1/2" SHALL BE MAINTAINED.
- THROUGH FRAME:** FOR INSTALLATION INTO METAL STUD, USE #10 TEK SCREWS OF SUFFICIENT LENGTH TO ACHIEVE MINIMUM 3 THREADS PENETRATION BEYOND METAL STRUCTURAL ELEMENT. MINIMUM 1/2" EDGE DISTANCE SHALL BE MAINTAINED.
- MINIMUM EMBEDMENT AND EDGE DISTANCE EXCLUDE WALL FINISHES, INCLUDING BUT NOT LIMITED TO STUCCO, FOAM, BRICK VENEER, AND SIDING.
- INSTALLATION ANCHORS AND ASSOCIATED HARDWARE MUST BE MADE OF CORROSION RESISTANT MATERIAL OR HAVE A CORROSION RESISTANT COATING.
- FOR HOLLOW BLOCK AND GROUT FILLED BLOCK, DO NOT INSTALL INSTALLATION ANCHORS INTO MORTAR JOINTS. EDGE DISTANCE IS MEASURED FROM FREE EDGE OF BLOCK OR EDGE OF MORTAR JOINT INTO FACE SHELL OF BLOCK.
- INSTALLATION ANCHORS SHALL BE INSTALLED IN ACCORDANCE WITH ANCHOR MANUFACTURER'S INSTALLATION INSTRUCTIONS, AND ANCHORS SHALL NOT BE USED IN SUBSTRATES WITH STRENGTHS LESS THAN THE MINIMUM STRENGTH SPECIFIED BY THE ANCHOR MANUFACTURER.
- INSTALLATION ANCHOR CAPACITIES FOR PRODUCTS HEREIN ARE BASED ON SUBSTRATE MATERIALS WITH THE FOLLOWING PROPERTIES:
 - WOOD - MINIMUM SPECIFIC GRAVITY OF 0.55.
 - CONCRETE - MINIMUM 3000 PSI COMPRESSIVE STRENGTH
 - HOLLOW/GROUT FILLED CMU - STRENGTH CONFORMANCE TO ASTM C90, MIN. F'm = 2000 PSI.
 - STEEL - MINIMUM 16 GA. (.054") MINIMUM TENSILE YIELD, Fy = 33 KSI.

GENERAL NOTES:

- THE PRODUCT SHOWN HEREIN IS DESIGNED AND MANUFACTURED TO COMPLY WITH THE CURRENT FLORIDA BUILDING CODE (FBC) AND INTERNATIONAL BUILDING CODE (IBC), EXCLUDING HVHZ AND HAS BEEN EVALUATED ACCORDING TO THE FOLLOWING:
 - AAMA 450-10
- ADEQUACY OF THE EXISTING STRUCTURAL CONCRETE/MASONRY AND 2X FRAMING AS A MAIN WIND FORCE RESISTING SYSTEM CAPABLE OF WITHSTANDING AND TRANSFERRING APPLIED PRODUCT LOADS TO THE FOUNDATION IS THE RESPONSIBILITY OF THE ENGINEER OR ARCHITECT OF RECORD FOR THE PROJECT OF INSTALLATION.
- 1X AND 2X BUCKS (WHEN USED) SHALL BE DESIGNED AND ANCHORED TO PROPERLY TRANSFER ALL LOADS TO THE STRUCTURE. BUCK DESIGN AND INSTALLATION IS THE RESPONSIBILITY OF THE ENGINEER OR ARCHITECT OF RECORD FOR THE PROJECT OF INSTALLATION.
- THE INSTALLATION DETAILS DESCRIBED HEREIN ARE GENERIC AND MAY NOT REFLECT ACTUAL CONDITIONS FOR A SPECIFIC SITE. IF SITE CONDITIONS CAUSE INSTALLATION TO DEVIATE FROM THE REQUIREMENTS DETAILED HEREIN, A LICENSED ENGINEER OR ARCHITECT SHALL PREPARE SITE SPECIFIC DOCUMENTS FOR USE WITH THIS DOCUMENT IN NON-HVHZ AREAS.
- APPROVED IMPACT PROTECTIVE SYSTEM **IS NOT REQUIRED** FOR THIS PRODUCT IN WIND ZONES 3 OR LESS PROVIDED WINDOW/DOOR ASSEMBLIES ARE MINIMUM WIND ZONE 3 IMPACT RATED. IN WIND ZONE 4, UNITS SHALL REQUIRE IMPACT PROTECTION.
- MULLION MATERIAL: PRESSURE TREATED FINGER-JOINTED EDGE GLUED PINE WITH AURALAST® (MINIMUM S.G. = 0.42)

TABLE OF CONTENTS		
SHEET	REVISION	SHEET DESCRIPTION
1	B	INSTALLATION & GENERAL NOTES
2	B	"JAMB TO JAMB" MULLION ASSEMBLIES
3	B	1" SOLID SPREAD" MULLION ASSEMBLIES
4	B	"2" SOLID SPREAD" MULLION ASSEMBLIES
5	B	"4" SOLID SPREAD" MULLION ASSEMBLIES
6	B	INSTALLATION CONDITIONS
7	B	TABLE A.1: ONE WAY "JAMB TO JAMB" OR 4" SPREAD DP TABLE
8	B	TABLE B.1: ONE WAY "1/4" STRUCTURAL MULL" DP TABLE
9	B	TABLES B.2 & B.3: TWO WAY "1/4" STRUCTURAL MULL" DP TABLE
10	B	TABLE C.1: ONE WAY "3/4" SOLID SPREAD MULL" DP TABLE
11	B	TABLES C.2 & C.3: TWO WAY "3/4" SOLID SPREAD MULL" DP TABLE
12	B	TABLE D.1: ONE WAY "1" SOLID SPREAD MULL" DP TABLE FOR USE WITH 2" AND 3" SPREAD MULL ASSEMBLIES
13	B	TABLES D.2 & D.3: TWO WAY "1" SOLID SPREAD MULL" DP TABLE FOR USE WITH 2" AND 3" SPREAD MULL ASSEMBLIES

TITLE: SITELINE OR W-5500 WOOD DOUBLE HUNG MULLION INSTALLATION & GENERAL NOTES

PREPARED BY: BUILDING DROPS, INC.
398 E. DANIA BEACH BLVD., STE. 338
DANIA BEACH, FL 33004
PH: (954) 959-8478
FAX: (954) 744-4738
WEB: www.buildingdrops.com

REMARKS	BY	DATE
6TH FBC CODE CHANGE	CL	9.6.17
W-5500 WOOD ADDITION	LL	6.11.19

THE INSTALLATION DETAILS DESCRIBED HEREIN ARE GENERIC AND MAY NOT REFLECT ACTUAL CONDITIONS FOR A SPECIFIC SITE. IF SITE CONDITIONS CAUSE INSTALLATION TO DEVIATE FROM THE REQUIREMENTS DETAILED HEREIN, A LICENSED ENGINEER OR ARCHITECT SHALL PREPARE SITE SPECIFIC DOCUMENTS FOR USE WITH THIS DOCUMENT

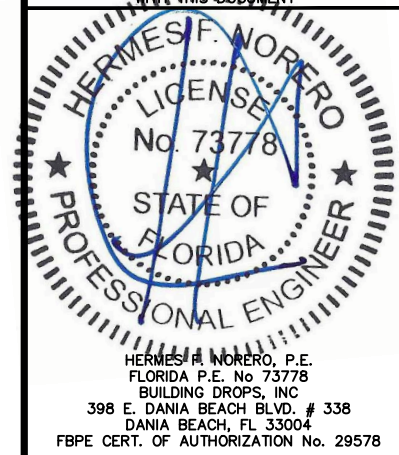

FL #: **FL21060**

DATE: **09.06.17**

DWG. BY: **CL** CHK. BY: **HFN**

SCALE: **NTS**

DWG. #: **JW063**

SHEET: **1**

OF 13

s:\projects\jeld-wen\fb-c-19-0536 - fb-c submittal - product name update, w-5500, fl17868, fl21060, fl26356.dwg, jw063.dwg 6/14/2019 2:40 PM

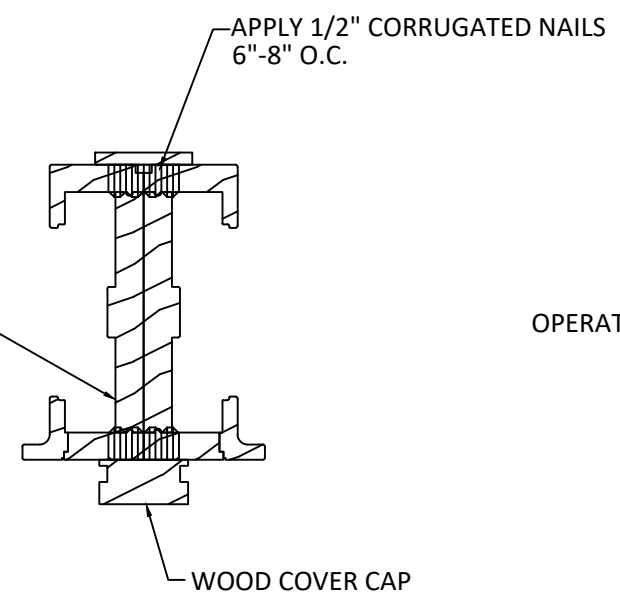

A
2
OPERATING-OPERATING
VERTICAL MULLION

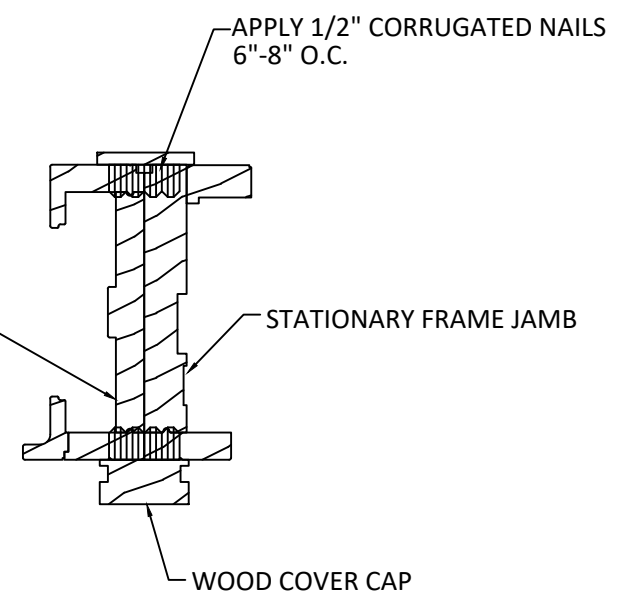

B
2
OPERATING-STATIONARY
VERTICAL MULLION

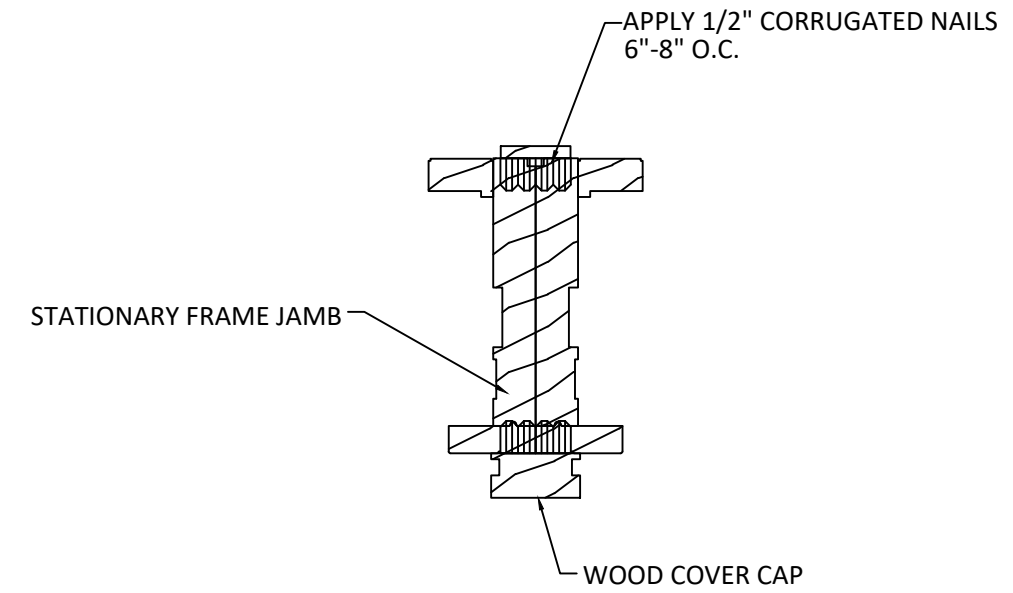

C
2
STATIONARY-STATIONARY
VERTICAL MULLION

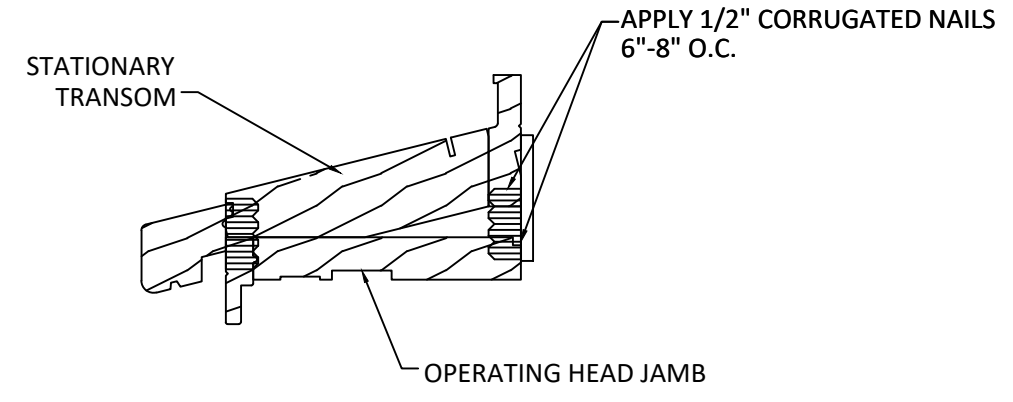

D
2
TRANSOM-OPERATING
HORIZONTAL MULL

- MULLION ASSEMBLY NOTES
- ASSEMBLIES SHOWN HEREIN, SHEET 2, MAY BE USED WITH DESIGN PRESSURE RATINGS SHOWN ON TABLE A.1: ONE WAY MULLIONS "JAMB TO JAMB" MULLS.
 - REFER TO SHEET 6 FOR ANCHORAGE REQUIREMENTS.



3737 LAKEPORT BLVD
KLAMATH FALLS, OR 97601
PH: (541) 882-3451 FAX: (541) 850-2609

TITLE:
SITELINE OR W-5500 WOOD DOUBLE HUNG MULLION
"JAMB TO JAMB" MULLION
ASSEMBLIES

PREPARED BY:
BUILDING DROPS, INC.
398 E. DANIA BEACH BLVD., STE. 338
DANIA BEACH, FL 33004
PH: (954) 999-8478
FAX: (954) 744-4738
WEB: www.buildingdrops.com

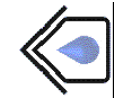

REMARKS	BY	DATE
6TH FBC CODE CHANGE	CL	9.6.17
W-5500 WOOD ADDITION	LL	6.11.19

THE INSTALLATION DETAILS DESCRIBED HEREIN ARE GENERIC AND MAY NOT REFLECT ACTUAL CONDITIONS FOR A SPECIFIC SITE. IF SITE CONDITIONS CAUSE INSTALLATION TO DEVIATE FROM THE REQUIREMENTS DETAILED HEREIN, A LICENSED ENGINEER OR ARCHITECT SHALL PREPARE SITE SPECIFIC DOCUMENTS FOR USE WITH THIS DOCUMENT



HERMES F. NORERO, P.E.
FLORIDA P.E. No. 73778
BUILDING DROPS, INC.
398 E. DANIA BEACH BLVD. # 338
DANIA BEACH, FL 33004
FBPE CERT. OF AUTHORIZATION No. 29578

FL #:
FL21060

DATE: **09.06.17**

DWG. BY: **CL** CHK. BY: **HFN**

SCALE: **NTS**

DWG. #: **JW063**

SHEET:
2

s:\projects\jeld-wen\fb-c-19-0536 - fbc submittal - product name update, w-5500, fl17868, fl21060, fl26356.dwg\jw063.dwg 6/14/2019 2:40 PM

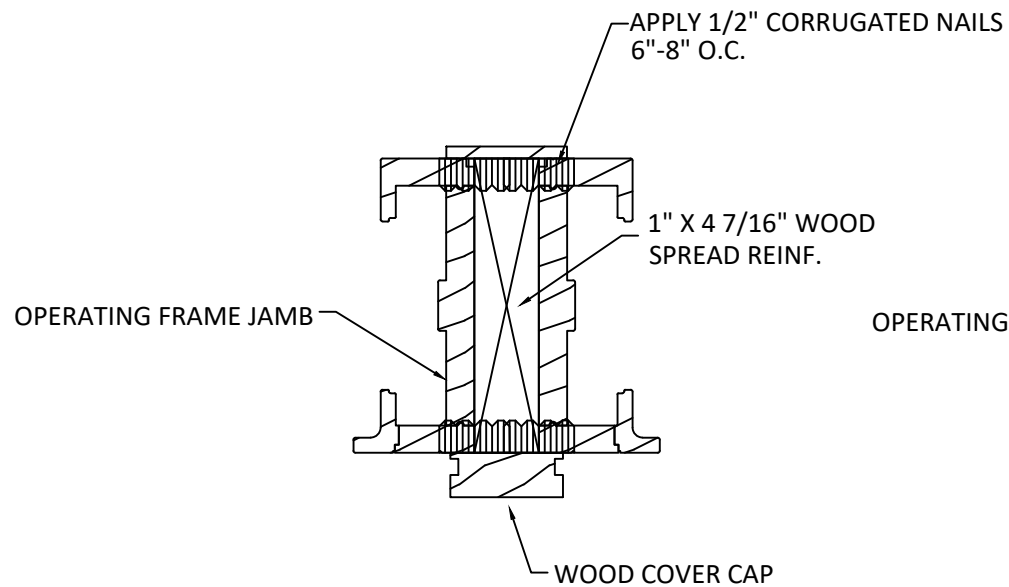

A
3 **OPERATING-OPERATING**
VERTICAL MULLION

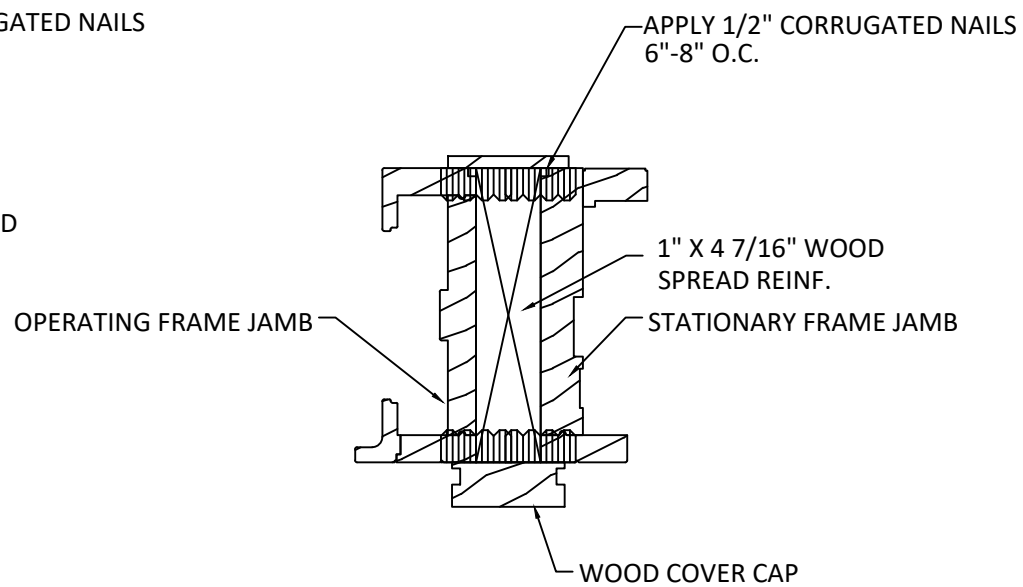

B
3 **OPERATING-STATIONARY**
VERTICAL MULLION

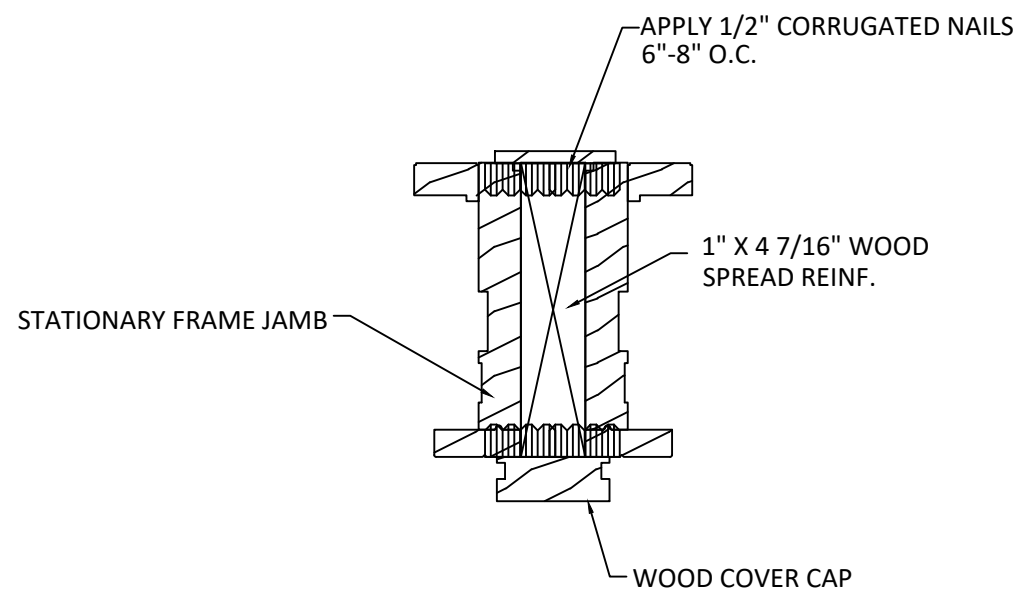

C
3 **STATIONARY-STATIONARY**
VERTICAL MULL

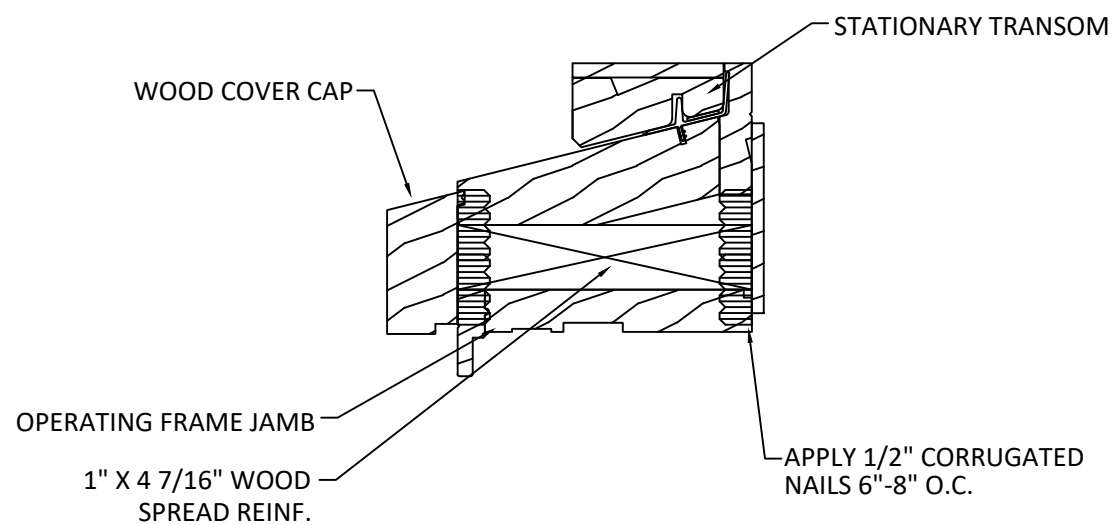

D
3 **TRANSOM-OPERATING**
HORIZONTAL MULL

- MULLION ASSEMBLY NOTES
- ASSEMBLIES SHOWN HEREIN, SHEET 3, MAY BE USED WITH DESIGN PRESSURE RATINGS SHOWN ON TABLE B.1: ONE WAY MULLIONS 1" SOLID SPREAD MULL AND TABLE B.2 TWO WAY MULLIONS 1" SOLID SPREAD MULL.
 - REFER TO SHEET 6 FOR ANCHORAGE REQUIREMENTS.

JELD-WEN
WINDOWS & DOORS

3737 LAKEPORT BLVD
KLAMATH FALLS, OR 97601
PH: (541) 882-3451 FAX: (541) 850-2609

TITLE:
SITELINE OR W-5500 WOOD DOUBLE HUNG MULLION
"3/4" OR 1" SOLID SPREAD MULLION"
ASSEMBLIES

PREPARED BY:
BUILDING DROPS, INC.
398 E. DANIA BEACH BLVD., STE. 338
DANIA BEACH, FL 33004
PH: (954) 999-8478
FAX: (954) 744-4738
WEB: www.buildingdrops.com

REMARKS	BY	DATE
6TH FBC CODE CHANGE	CL	9.6.17
W-5500 WOOD ADDITION	LL	6.11.19

THE INSTALLATION DETAILS DESCRIBED HEREIN ARE GENERIC AND MAY NOT REFLECT ACTUAL CONDITIONS FOR A SPECIFIC SITE. IF SITE CONDITIONS CAUSE INSTALLATION TO DEVIATE FROM THE REQUIREMENTS DETAILED HEREIN, A LICENSED ENGINEER OR ARCHITECT SHALL PREPARE SITE SPECIFIC DOCUMENTS FOR USE WITH THIS DOCUMENT

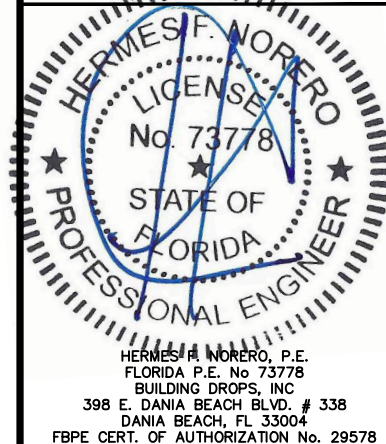

FL #:
FL21060

DATE: **09.06.17**

DWG. BY: **CL** CHK. BY: **HFN**

SCALE: **NTS**

DWG. #: **JW063**

SHEET:
3

6/14/2019 2:40 PM
 s:\projects\jeld-wen\fb-c-19-0536 - fbc submittal - product name update, w-5500, fl21060, fl26356.dwg
 s:\projects\jeld-wen\fb-c-19-0536 - fbc submittal - product name update, w-5500, fl21060, fl26356.dwg

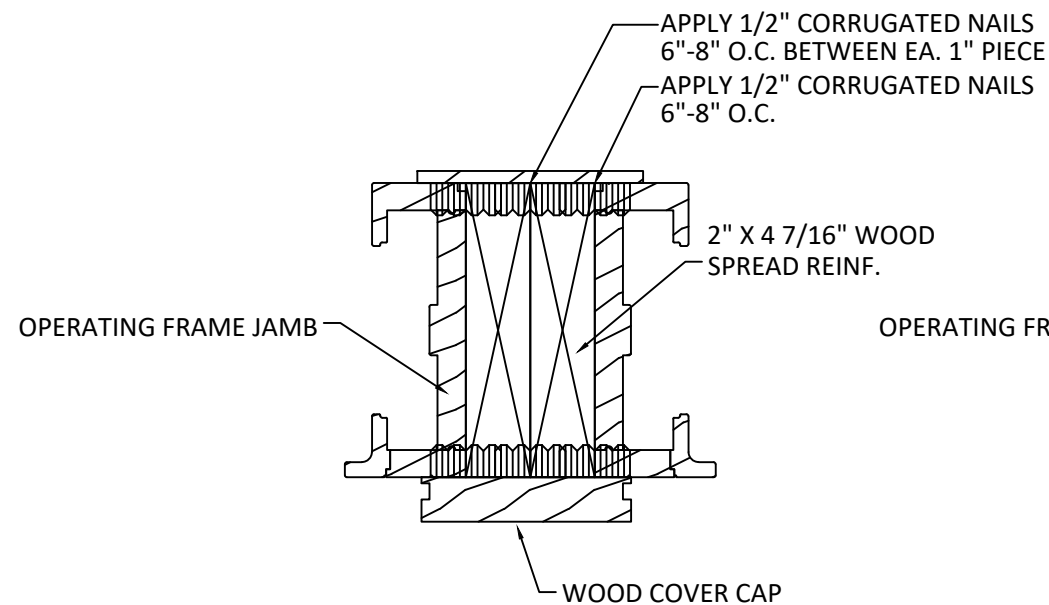

A
4
OPERATING-OPERATING
VERTICAL MULLION

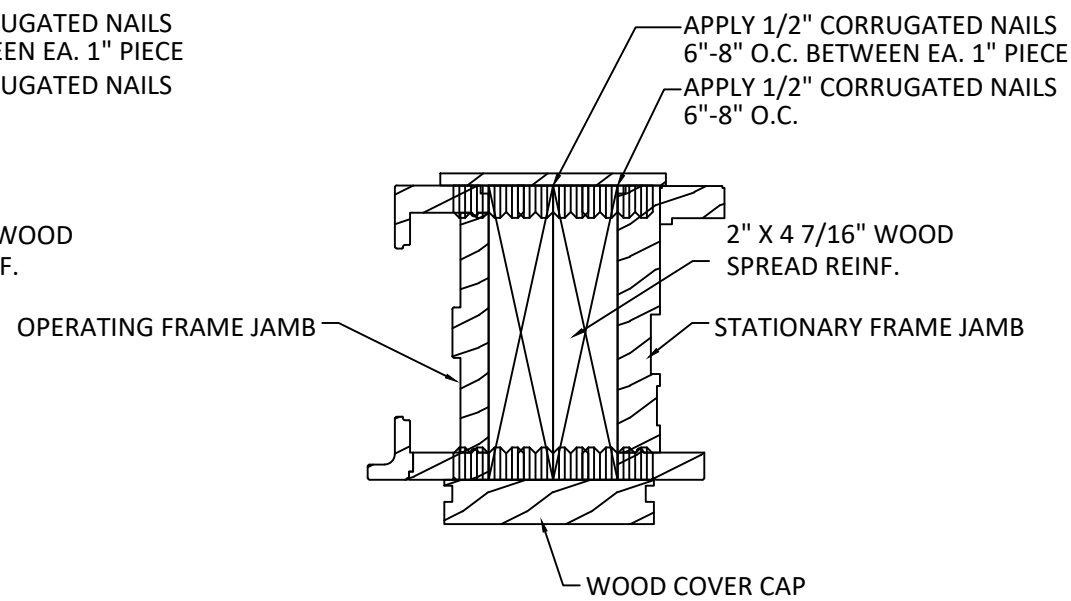

B
4
OPERATING-STATIONARY
VERTICAL MULLION

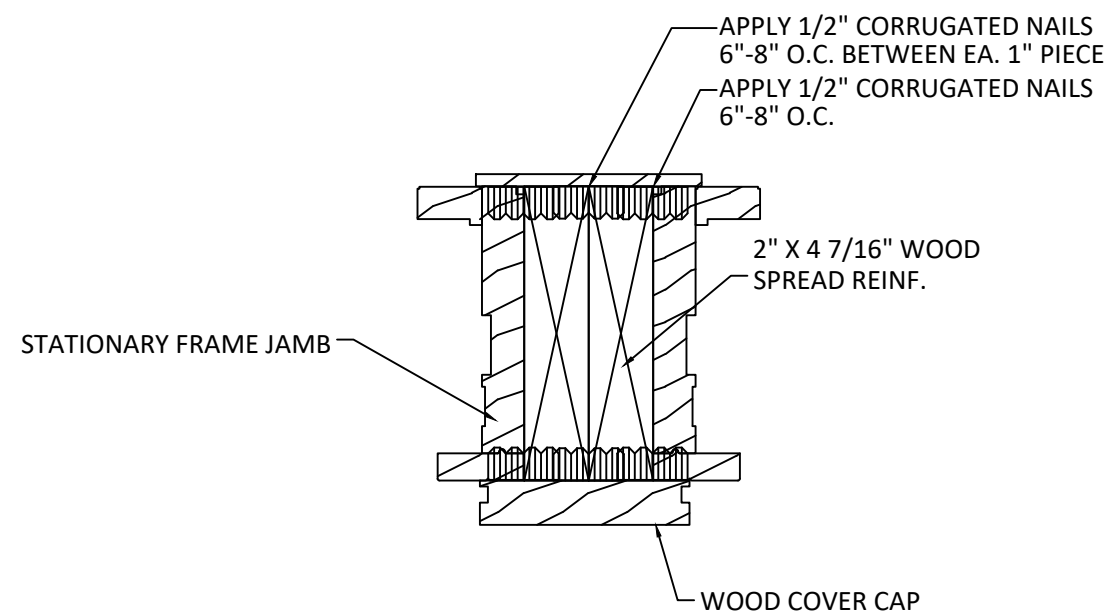

C
4
STATIONARY-STATIONARY
VERTICAL MULL

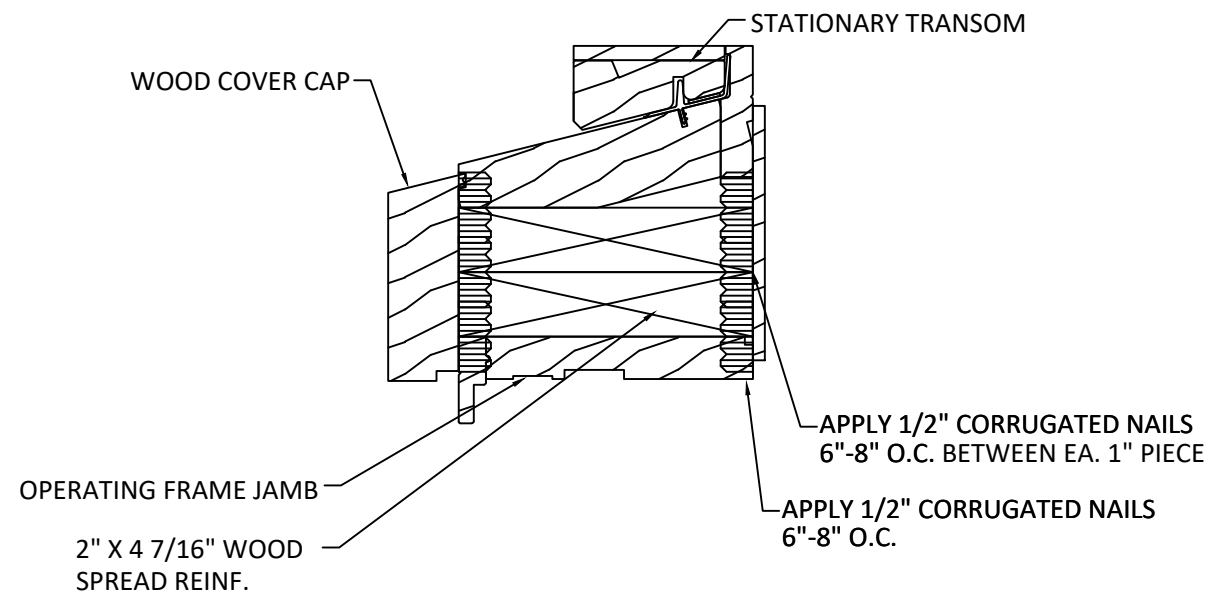

D
4
TRANSOM-OPERATING
HORIZONTAL MULL

- MULLION ASSEMBLY NOTES
- ASSEMBLIES SHOWN HEREIN, SHEET 4, MAY BE USED WITH DESIGN PRESSURE RATINGS SHOWN ON TABLE C.1: ONE WAY MULLIONS 2" SOLID SPREAD MULL AND TABLE C.2 TWO WAY MULLIONS 2" SOLID SPREAD MULL.
 - REFER TO SHEET 6 FOR ANCHORAGE REQUIREMENTS.

JELD-WEN
WINDOWS & DOORS

3737 LAKEPORT BLVD
KLAMATH FALLS, OR 97601
PH: (541) 882-3451 FAX: (541) 850-2609

TITLE:
SITELINE OR W-5500 WOOD DOUBLE HUNG MULLION
"2" SOLID SPREAD MULLION"
ASSEMBLIES

PREPARED BY:
BUILDING DROPS, INC.
398 E. DANIA BEACH BLVD., STE. 338
DANIA BEACH, FL 33004
PH: (954) 999-8478
FAX: (954) 744-4738
WEB: www.buildingdrops.com

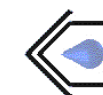

REMARKS	BY	DATE
6TH FBC CODE CHANGE	CL	9.6.17
W-5500 WOOD ADDITION	LL	6.11.19

THE INSTALLATION DETAILS DESCRIBED HEREIN ARE GENERIC AND MAY NOT REFLECT ACTUAL CONDITIONS FOR A SPECIFIC SITE. IF SITE CONDITIONS CAUSE INSTALLATION TO DEVIATE FROM THE REQUIREMENTS DETAILED HEREIN, A LICENSED ENGINEER OR ARCHITECT SHALL PREPARE SITE SPECIFIC DOCUMENTS FOR USE WITH THIS DOCUMENT

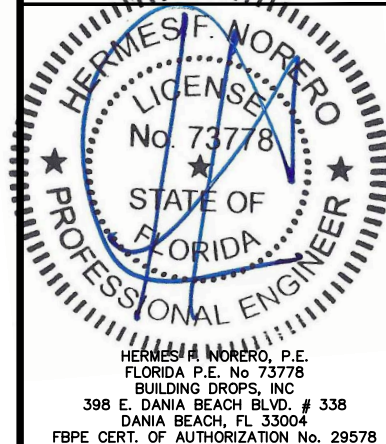

FL #:
FL21060

DATE: **09.06.17**

DWG. BY: **CL** CHK. BY: **HFN**

SCALE: **NTS**

DWG. #: **JW063**

SHEET:

4

s:\projects\jeld-wen\fb-c-19-0536 - fbc submittal - product name update, w-5500, fl17868, fl21060, fl26356.dwg\jw063.dwg 6/14/2019 2:40 PM

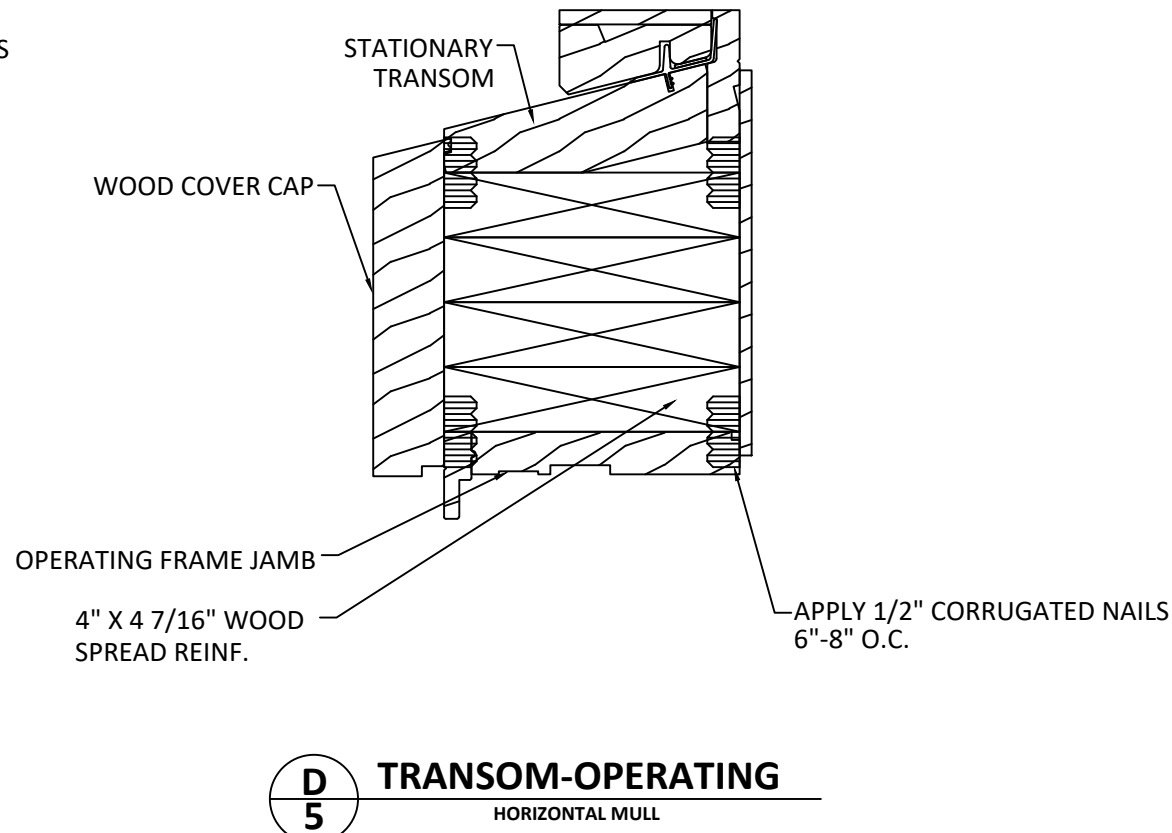
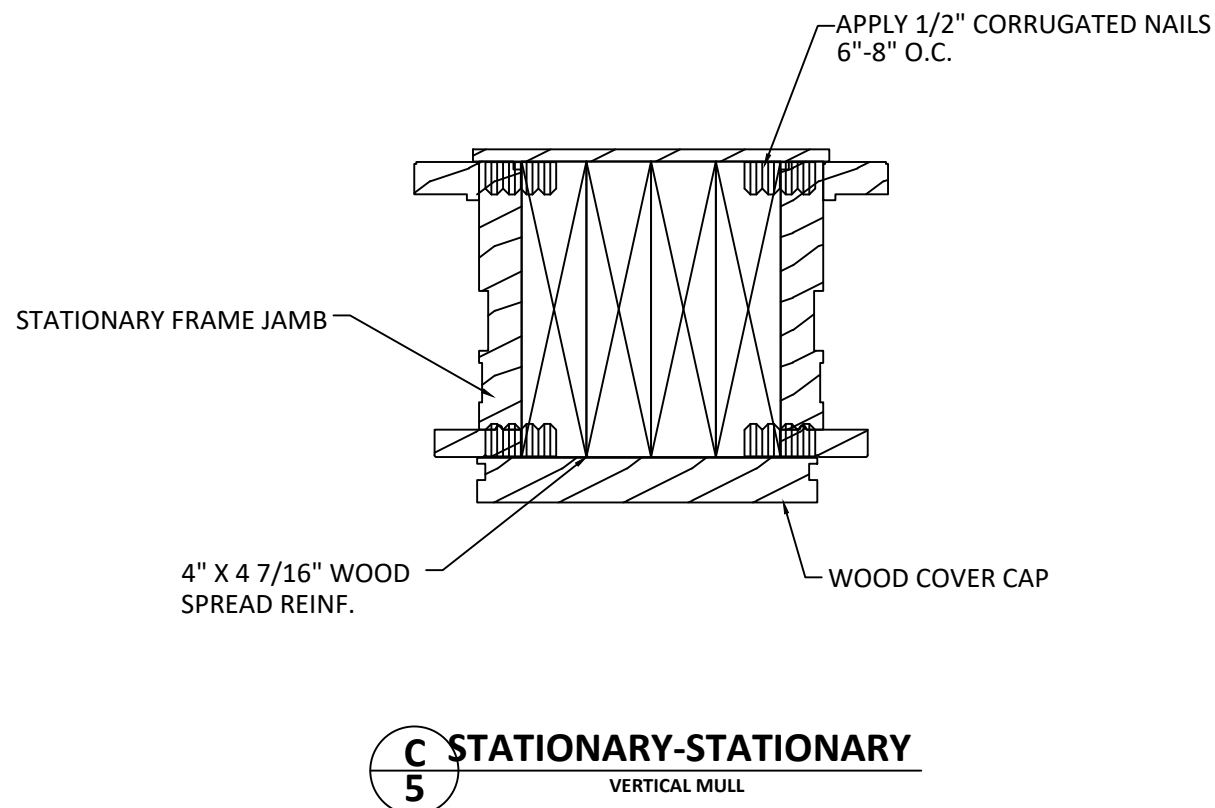
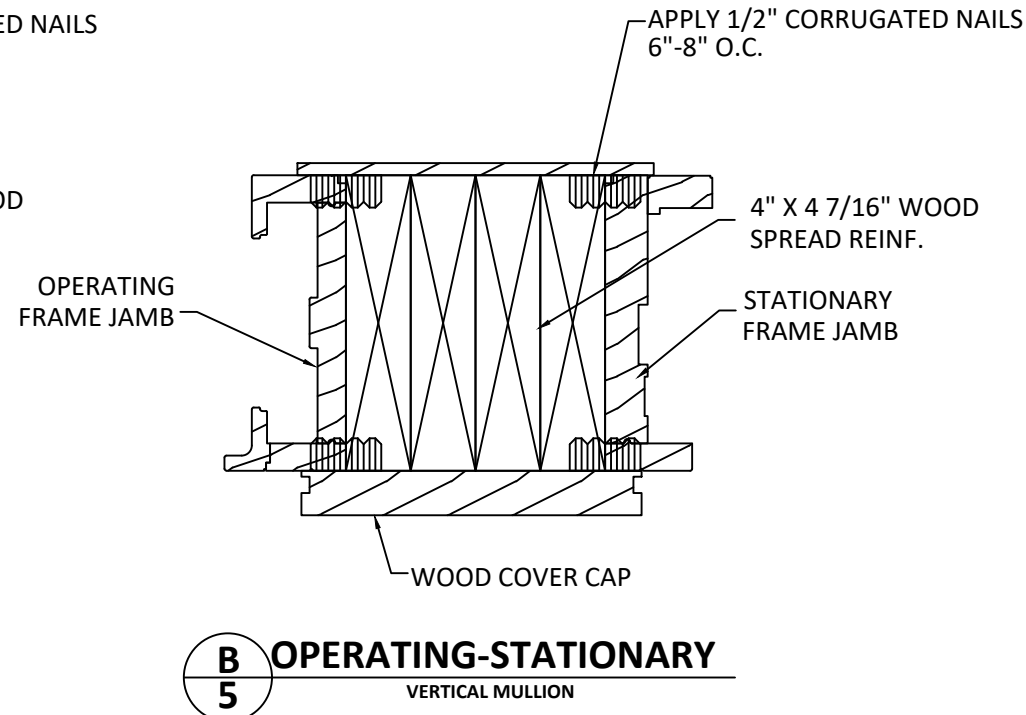
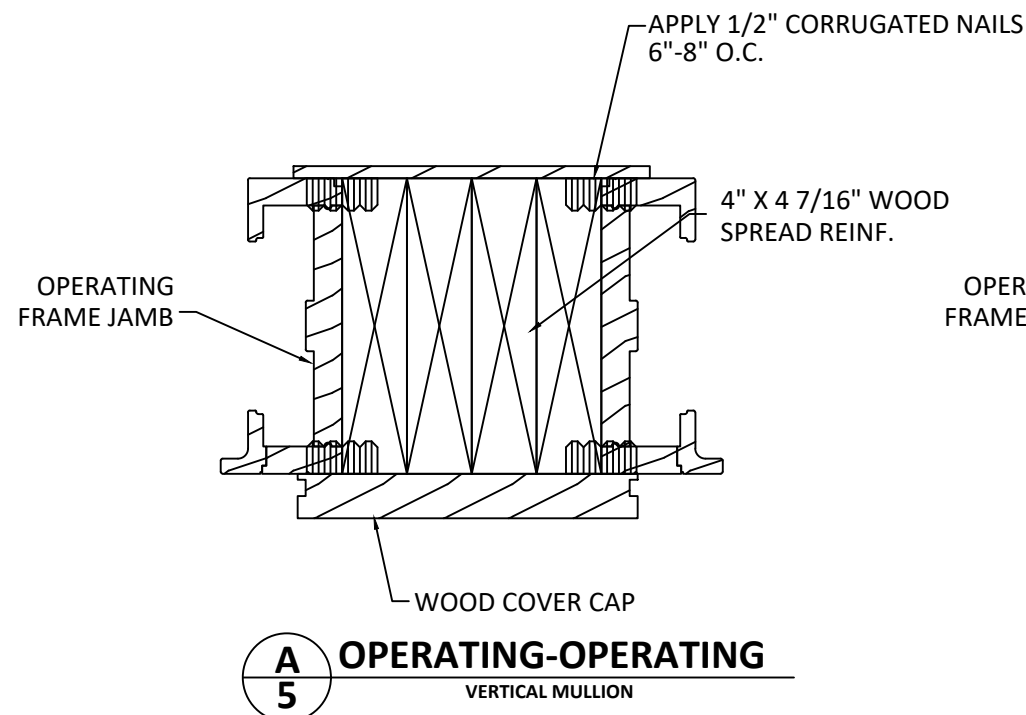

- MULLION ASSEMBLY NOTES**
- ASSEMBLIES SHOWN HEREIN, SHEET 5, MAY BE USED WITH DESIGN PRESSURE RATINGS SHOWN ON TABLE D.1: ONE WAY MULLIONS 4" SOLID SPREAD MULL AND TABLE D.2 TWO WAY MULLIONS 4" SOLID SPREAD MULL.
 - REFER TO SHEET 6 FOR ANCHORAGE REQUIREMENTS.

JELD-WEN
WINDOWS & DOORS

3737 LAKEPORT BLVD
KLAMATH FALLS, OR 97601
PH: (541) 882-3451 FAX: (541) 850-2609

TITLE: SITELINE OR W-5500 WOOD DOUBLE HUNG MULLION "4" SOLID SPREAD MULLION" ASSEMBLIES

PREPARED BY: BUILDING DROPS, INC.
398 E. DANIA BEACH BLVD., STE. 338
DANIA BEACH, FL 33004
PH: (954) 999-8478
FAX: (954) 744-4738
WEB: www.buildingdrops.com

REMARKS	BY	DATE
6TH FBC CODE CHANGE	CL	9.6.17
W-5500 WOOD ADDITION	LL	6.11.19

THE INSTALLATION DETAILS DESCRIBED HEREIN ARE GENERIC AND MAY NOT REFLECT ACTUAL CONDITIONS FOR A SPECIFIC SITE. IF SITE CONDITIONS CAUSE INSTALLATION TO DEVIATE FROM THE REQUIREMENTS DETAILED HEREIN, A LICENSED ENGINEER OR ARCHITECT SHALL PREPARE SITE SPECIFIC DOCUMENTS FOR USE WITH THIS DOCUMENT

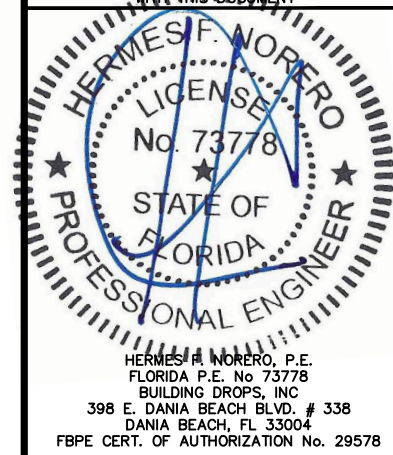

FL #: **FL21060**

DATE: **09.06.17**

DWG. BY: **CL** CHK. BY: **HFN**

SCALE: **NTS**

DWG. #: **JW063**

SHEET: **5**

6/14/2019 2:40 PM
 s:\projects\jeld-wen\fb-c-19-0536 - fb-c submittal - product name update, w-5500, fl21060, fl26356\dwg\jw063.dwg

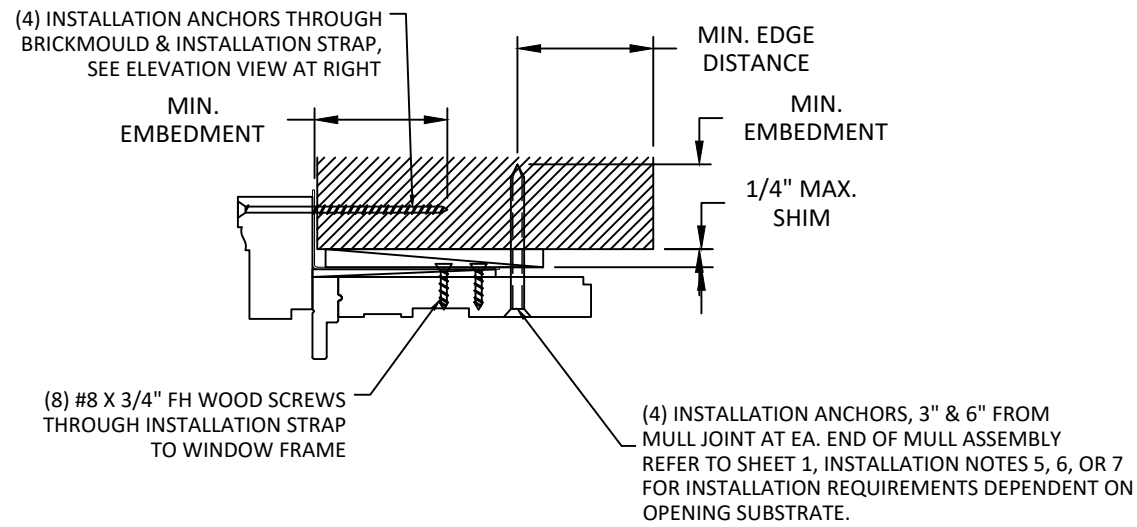

A
6 **VERTICAL SECTION**
TYPICAL INSTALLATION
TYPICAL FOR ALL FRAMES & JAMBS

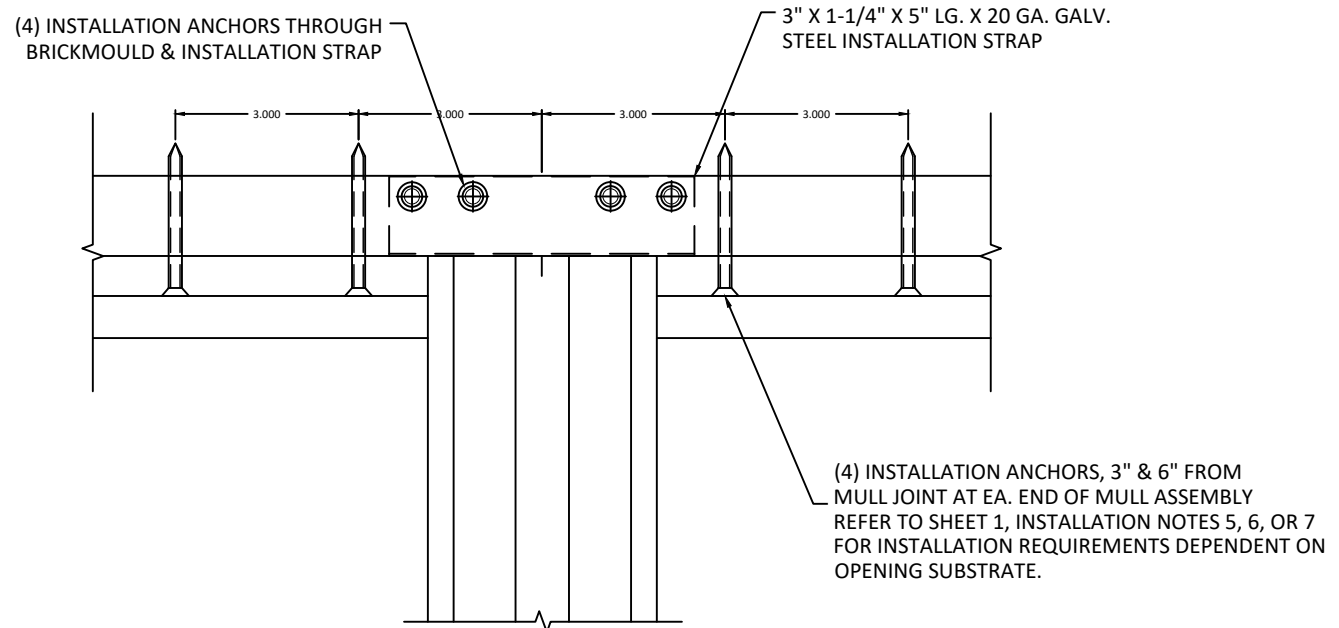

B
6 **ENLARGED ELEVATION**
TYPICAL INSTALLATION
TYPICAL FOR ALL FRAMES

E
6 **PLAN VIEW**
TYPICAL INSTALLATION
AT EA. END OF MULL

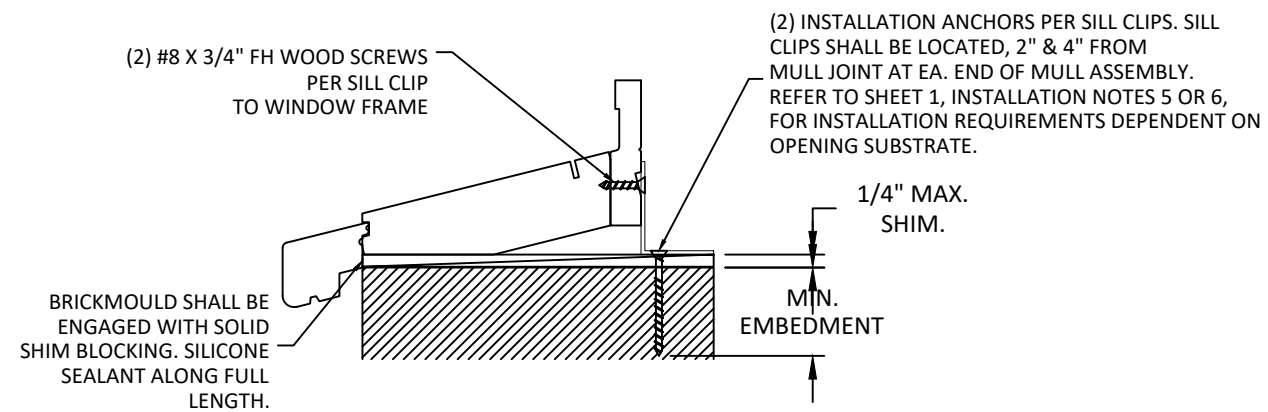
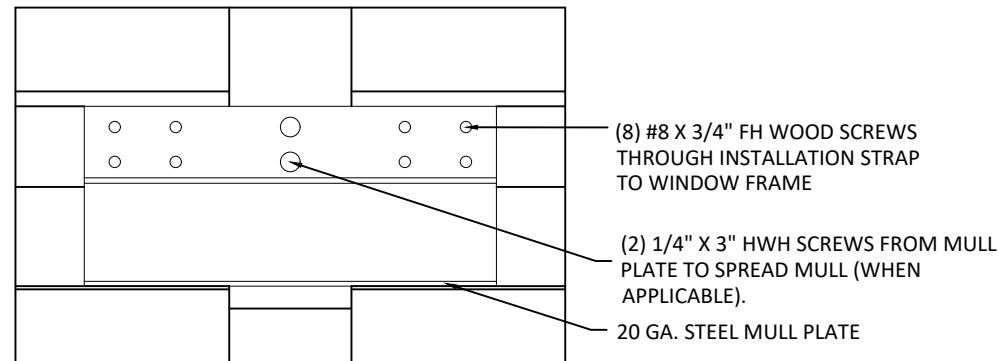

C
6 **VERTICAL SECTION**
TYPICAL SILL INSTALLATION

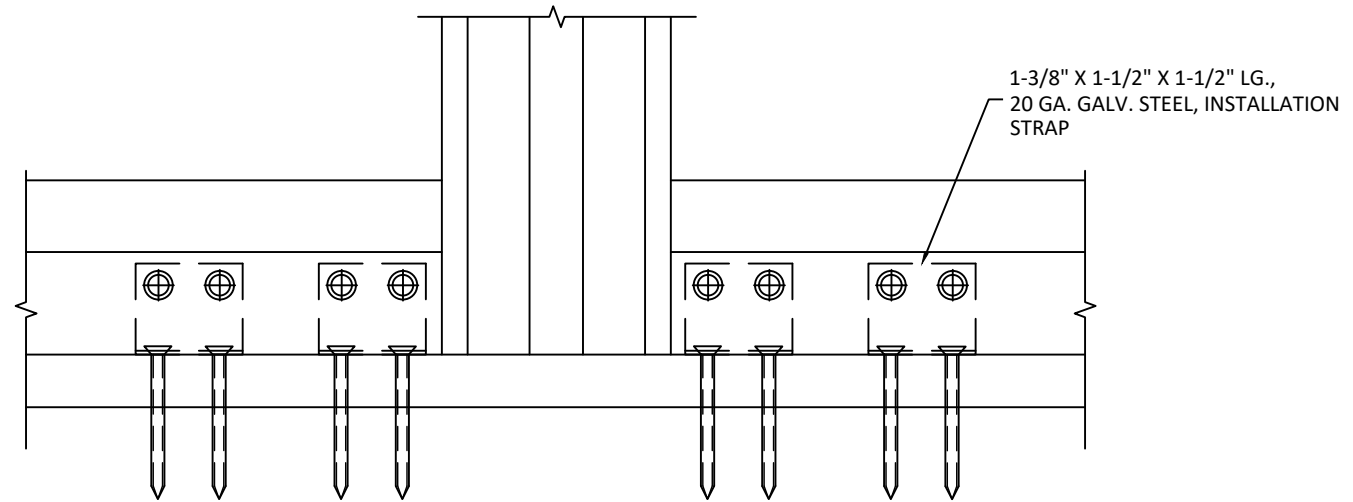

D
6 **ENLARGED ELEVATION**
TYPICAL SILL INSTALLATION

JELD-WEN
WINDOWS & DOORS

3737 LAKEPORT BLVD
KLAMATH FALLS, OR 97601
PH: (541) 882-3451 FAX: (541) 850-2609

TITLE:
SITELINE OR W-5500 WOOD DOUBLE HUNG MULLION
INSTALLATION CONDITIONS

PREPARED BY:
BUILDING DROPS, INC.
398 E. DANIA BEACH BLVD., STE. 338
DANIA BEACH, FL 33004
PH: (954) 959-8478
FAX: (954) 744-4738
WEB: www.buildingdrops.com

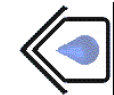

REMARKS	BY	DATE
6TH FBC CODE CHANGE	CL	9.6.17
W-5500 WOOD ADDITION	LL	6.11.19

THE INSTALLATION DETAILS DESCRIBED HEREIN ARE GENERIC AND MAY NOT REFLECT ACTUAL CONDITIONS FOR A SPECIFIC SITE. IF SITE CONDITIONS CAUSE INSTALLATION TO DEVIATE FROM THE REQUIREMENTS DETAILED HEREIN, A LICENSED ENGINEER OR ARCHITECT SHALL PREPARE SITE SPECIFIC DOCUMENTS FOR USE WITH THIS DOCUMENT

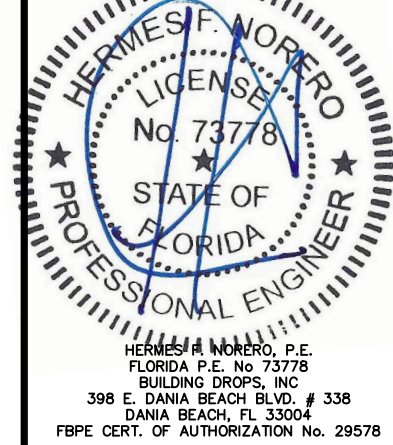

FL #:
FL21060

DATE: **09.06.17**

DWG. BY: **CL** CHK. BY: **HFN**

SCALE: **NTS**

DWG. #: **JW063**

SHEET:
6
OF 13

s:\projects\jeld-wen\fb-c-19-0536 - fbc submittal - product name update, w-5500, fl17868, fl21060, fl26356.dwg\jw063.dwg 6/14/2019 2:40 PM

Maximum design pressure capacity chart (psf):

L - Mull Length (in)	W - Tributary Width (in)														
	18.0	24.0	30.0	36.0	39.0	42.0	45.0	48.0	51.0	54.0	57.0	60.0	63.0	66.0	72.0
24.0	65.0	65.0	65.0	65.0	65.0	65.0	65.0	65.0	65.0	65.0	65.0	65.0	65.0	65.0	65.0
30.0	65.0	65.0	65.0	65.0	65.0	65.0	65.0	65.0	65.0	65.0	65.0	65.0	65.0	65.0	65.0
36.0	65.0	65.0	65.0	65.0	65.0	65.0	65.0	65.0	65.0	65.0	65.0	65.0	65.0	65.0	65.0
42.0	65.0	65.0	65.0	65.0	65.0	65.0	65.0	65.0	65.0	65.0	65.0	65.0	65.0	65.0	65.0
48.0	65.0	65.0	65.0	65.0	65.0	65.0	65.0	65.0	65.0	65.0	65.0	65.0	65.0	65.0	65.0
54.0	65.0	65.0	65.0	65.0	63.3	60.8	59.0	57.7	56.9	56.6	56.6	56.6	56.6	56.6	56.6
60.0	65.0	65.0	60.0	52.1	49.3	47.0	45.2	43.7	42.7	41.9	41.5	41.3	41.3	41.3	41.3
61.4	65.0	65.0	57.2	49.5	46.7	44.5	42.7	41.3	40.2	39.4	38.9	38.6	38.6	38.6	38.6
72.0	65.0	49.6	40.6	34.7	32.6	30.8	29.3	28.0	27.0	26.1	25.4	24.9	24.4	24.1	23.9
78.0	55.3	42.1	34.3	29.2	27.3	25.8	24.4	23.3	22.3	21.5	20.9	20.3	19.8	19.5	19.0
84.0	47.6	36.1	29.3	24.9	23.3	21.9	20.7	19.7	18.8	18.1	17.5	16.9	16.5	16.1	15.5
90.0	41.4	31.3	25.4	21.5	20.1	18.8	17.8	16.9	16.1	15.4	-	-	-	-	-
96.0	36.3	27.5	22.2	18.8	17.5	16.4	15.5	-	-	-	-	-	-	-	-
102.0	31.8	24.1	19.6	16.6	15.4	-	-	-	-	-	-	-	-	-	-
108.0	26.8	20.3	16.4	-	-	-	-	-	-	-	-	-	-	-	-
114.0	22.7	17.2	-	-	-	-	-	-	-	-	-	-	-	-	-
120.0	19.5	-	-	-	-	-	-	-	-	-	-	-	-	-	-

TABLE A.1: ONE WAY MULLIONS "JAMB TO JAMB"

- 'ONE-WAY' MULLIONS REFER TO EITHER VERTICAL RIBBON OR HORIZONTAL STACKED ASSEMBLIES SIMILAR TO THOSE DIAGRAMMED ON THIS SHEET.
- THE DESIGN PRESSURE TABLE HEREIN APPLIES TO MULLION MEMBERS ON SHEETS 2 (JAMB TO JAMB).
- WINDOW ASSEMBLIES MAY BE INTERMIXED COMBINATIONS OF FRAMES & MULLIONS AS SHOWN ON SHEETS 2-5.
- DESIGN PRESSURES LISTED SHALL BE READ AS POSITIVE AND NEGATIVE PRESSURES.
- DESIGN PRESSURES SHALL BE GOVERNED BY THE LESSER OF THE MULLION ASSEMBLY (LISTED IN TABLE) OR INDIVIDUAL WINDOW UNIT.
- INDIVIDUAL WINDOW UNITS SHALL BE UNDER SEPARATE APPROVAL.

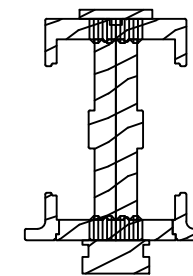

**JAMB TO JAMB
TYPICAL**

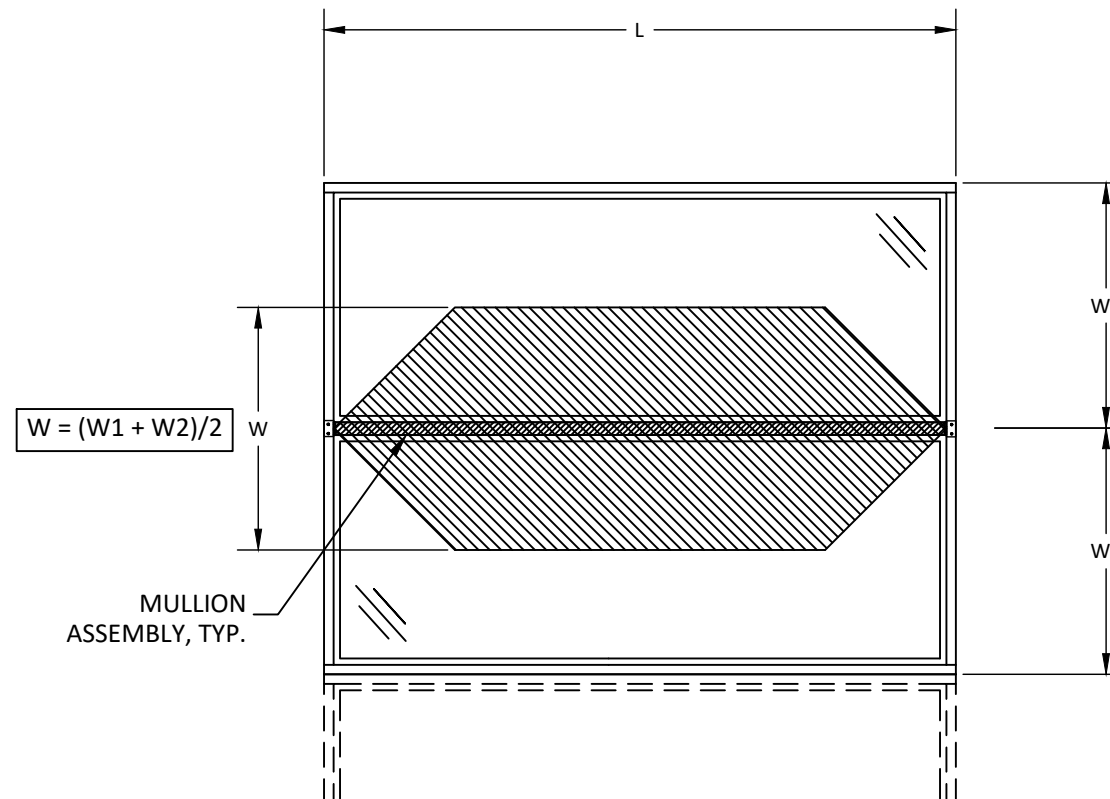
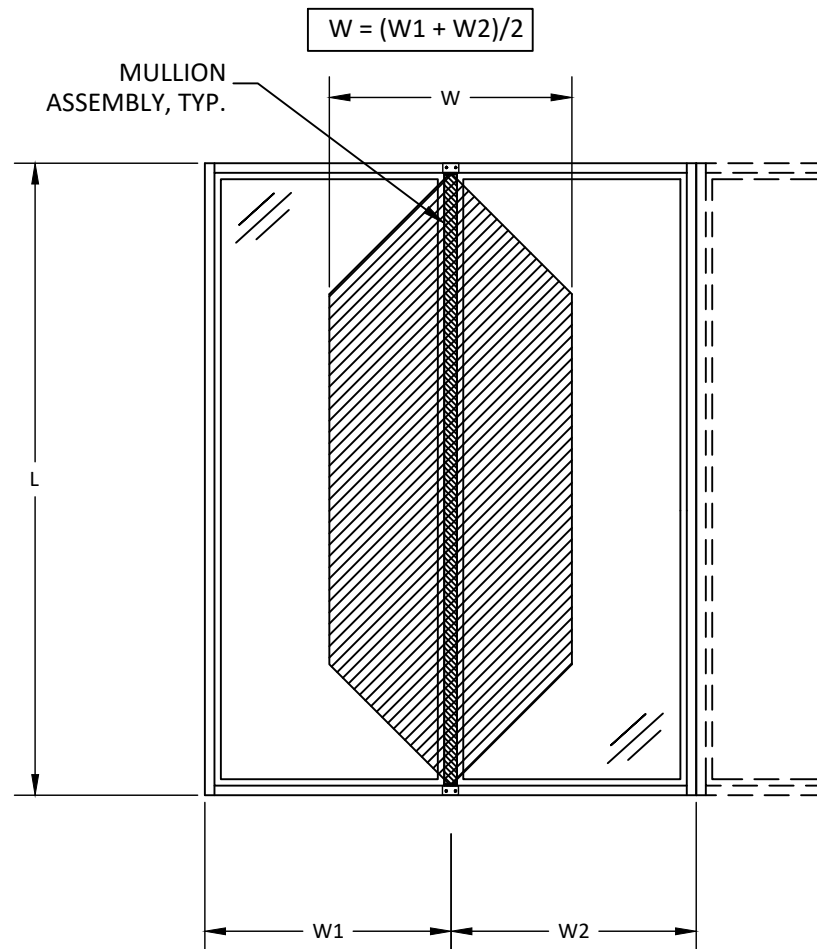

3737 LAKEPORT BLVD
KLAMATH FALLS, OR 97601
PH: (541) 882-3451 FAX: (541) 850-2609

TITLE:
SITELINE OR W-5500 WOOD DOUBLE HUNG MULLION
ONE WAY "JAMB TO JAMB"
MULLION DP TABLE

PREPARED BY:
BUILDING DROPS, INC.
398 E. DANIA BEACH BLVD., STE. 338
DANIA BEACH, FL 33004
PH: (954) 959-8478
FAX: (954) 744-4738
WEB: www.buildingdrops.com

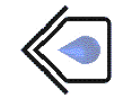

REMARKS	BY	DATE
6TH FBC CODE CHANGE	CL	9.6.17
W-5500 WOOD ADDITION	LL	6.11.19

THE INSTALLATION DETAILS DESCRIBED HEREIN ARE GENERIC AND MAY NOT REFLECT ACTUAL CONDITIONS FOR A SPECIFIC SITE. IF SITE CONDITIONS CAUSE INSTALLATION TO DEVIATE FROM THE REQUIREMENTS DETAILED HEREIN, A LICENSED ENGINEER OR ARCHITECT SHALL PREPARE SITE SPECIFIC DOCUMENTS FOR USE WITH THIS DOCUMENT

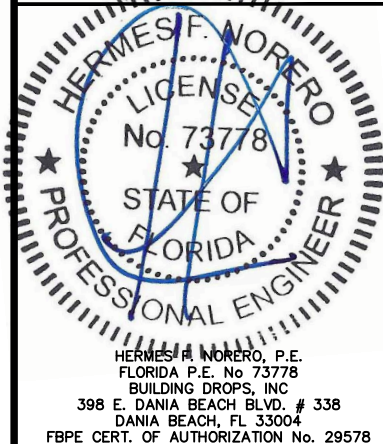

FL #:
FL21060

DATE: **09.06.17**

DWG. BY: **CL** CHK. BY: **HFN**

SCALE: **NTS**

DWG. #: **JW063**

SHEET:

7

s:\projects\jeld-wen\fb-c-19-0536 - fbc submittal - product name update, w-5500, fl17868, fl21060, fl26356.dwg\jw063.dwg 6/14/2019 2:40 PM

Maximum design pressure capacity chart (psf):															
L - Mull Length (in)	W - Tributary Width (in)														
	18.0	24.0	30.0	36.0	39.0	42.0	45.0	48.0	51.0	54.0	57.0	60.0	63.0	66.0	72.0
24.0	65.0	65.0	65.0	65.0	65.0	65.0	65.0	65.0	65.0	65.0	65.0	65.0	65.0	65.0	65.0
30.0	65.0	65.0	65.0	65.0	65.0	65.0	65.0	65.0	65.0	65.0	65.0	65.0	65.0	65.0	65.0
36.0	65.0	65.0	65.0	65.0	65.0	65.0	65.0	65.0	65.0	65.0	65.0	65.0	65.0	65.0	65.0
42.0	65.0	65.0	65.0	65.0	65.0	65.0	65.0	65.0	65.0	65.0	65.0	65.0	65.0	65.0	65.0
48.0	65.0	65.0	65.0	65.0	65.0	65.0	65.0	65.0	65.0	65.0	65.0	65.0	65.0	65.0	65.0
54.0	65.0	65.0	65.0	65.0	65.0	65.0	65.0	65.0	65.0	65.0	65.0	65.0	65.0	65.0	65.0
60.0	65.0	65.0	65.0	65.0	65.0	65.0	65.0	65.0	65.0	65.0	65.0	65.0	65.0	65.0	65.0
66.0	65.0	65.0	65.0	65.0	65.0	65.0	65.0	65.0	65.0	65.0	65.0	65.0	65.0	65.0	65.0
72.0	65.0	65.0	65.0	65.0	65.0	65.0	65.0	65.0	64.7	62.3	60.3	58.7	57.4	56.4	55.1
78.0	65.0	65.0	65.0	65.0	63.1	59.4	56.3	53.7	51.5	49.7	48.1	46.8	45.7	44.9	43.8
84.0	65.0	65.0	65.0	57.5	53.7	50.5	47.8	45.4	43.5	41.7	40.3	39.0	38.0	37.1	35.8
90.0	65.0	65.0	58.7	49.7	46.3	43.5	41.1	39.0	37.2	35.6	34.3	33.1	32.1	31.3	29.9
96.0	65.0	63.4	51.3	43.4	40.4	37.9	35.7	33.8	32.2	30.8	29.6	28.5	27.6	26.8	25.4
102.0	65.0	53.0	43.0	36.4	33.9	31.8	30.0	28.4	27.0	25.9	24.8	23.9	23.1	22.5	21.3
108.0	58.9	44.6	36.1	30.5	28.4	26.6	25.0	23.7	22.5	21.5	20.6	19.8	19.2	18.5	17.5
114.0	50.0	37.8	30.6	25.8	24.0	22.4	21.1	20.0	19.0	18.1	17.3	16.7	16.1	15.5	-
120.0	42.8	32.3	26.1	22.0	20.5	19.1	18.0	17.0	16.1	15.4	-	-	-	-	-

TABLE B.1: ONE WAY MULLIONS 1" SPREAD MULLION

- ONE-WAY' MULLIONS REFER TO EITHER VERTICAL RIBBON OR HORIZONTAL STACKED ASSEMBLIES SIMILAR TO THOSE DIAGRAMMED ON THIS SHEET.
- THE DESIGN PRESSURE TABLE HEREIN APPLIES TO MULLION MEMBERS ON SHEET 3 ONLY.
- WINDOW ASSEMBLIES MAY BE INTERMIXED COMBINATIONS OF FRAMES & MULLIONS AS SHOWN ON SHEETS 2-5.
- DESIGN PRESSURES LISTED SHALL BE READ AS POSITIVE AND NEGATIVE PRESSURES.
- DESIGN PRESSURES SHALL BE GOVERNED BY THE LESSER OF THE MULLION ASSEMBLY (LISTED IN TABLE) OR INDIVIDUAL WINDOW UNIT.
- INDIVIDUAL WINDOW UNITS SHALL BE UNDER SEPARATE APPROVAL.

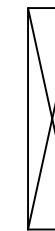

1" SPREAD MULLION

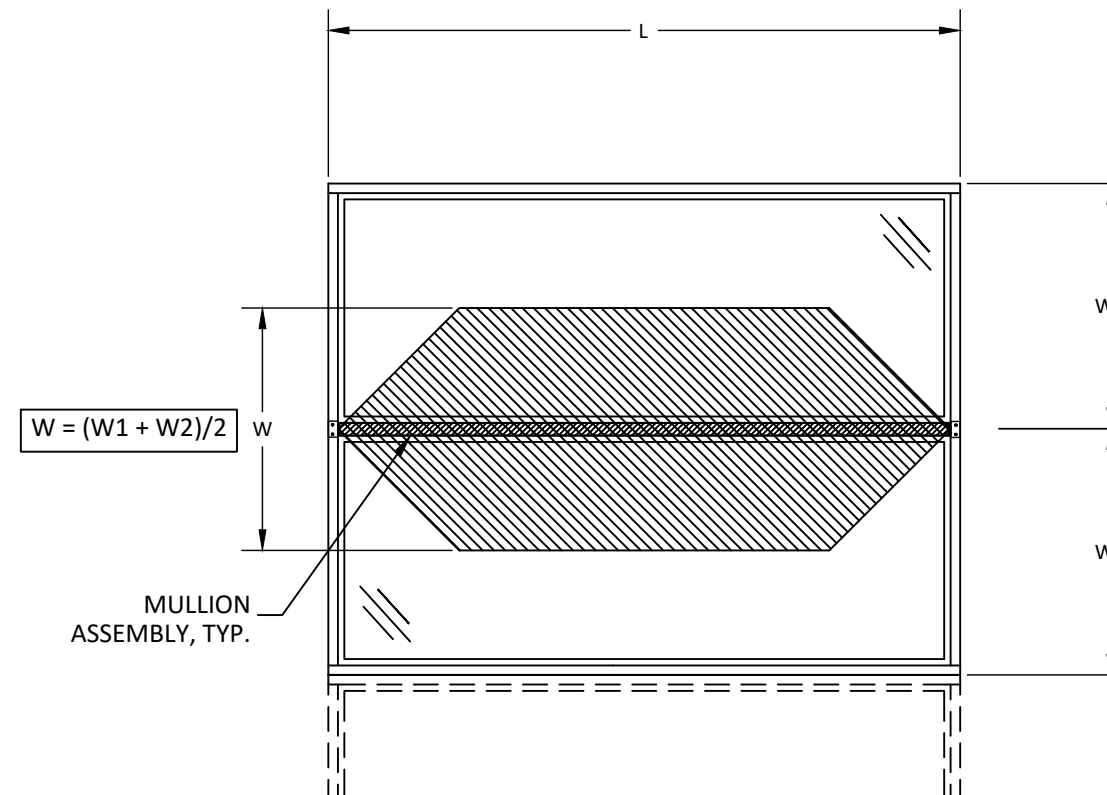
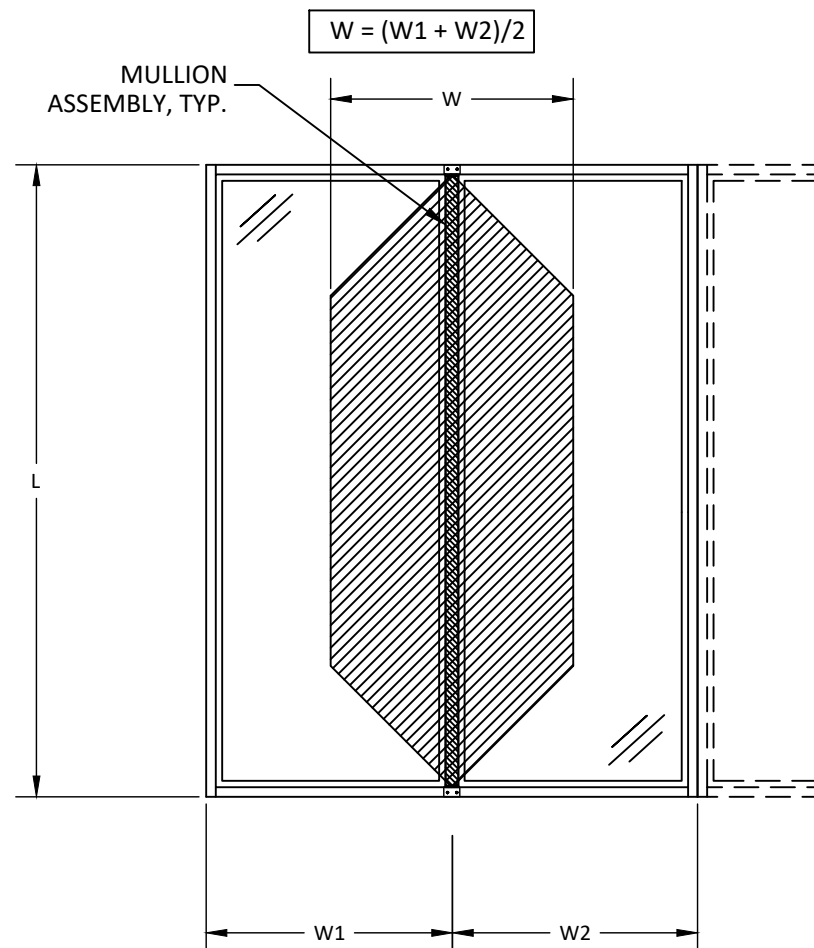

3737 LAKEPORT BLVD
KLAMATH FALLS, OR 97601
PH: (541) 882-3451 FAX: (541) 850-2609

TITLE:
SITELINE OR W-5500 WOOD DOUBLE HUNG MULLION
ONE WAY "1/4" STRUCTURAL
MULLION"

PREPARED BY:
BUILDING DROPS, INC.
398 E. DANIA BEACH BLVD., STE. 338
DANIA BEACH, FL 33004
PH: (954) 999-8478
FAX: (954) 744-4738
WEB: www.buildingdrops.com



REMARKS	BY	DATE
6TH FBC CODE CHANGE	CL	9.6.17
W-5500 WOOD ADDITION	LL	6.11.19

THE INSTALLATION DETAILS DESCRIBED HEREIN ARE GENERIC AND MAY NOT REFLECT ACTUAL CONDITIONS FOR A SPECIFIC SITE. IF SITE CONDITIONS CAUSE INSTALLATION TO DEVIATE FROM THE REQUIREMENTS DETAILED HEREIN, A LICENSED ENGINEER OR ARCHITECT SHALL PREPARE SITE SPECIFIC DOCUMENTS FOR USE WITH THIS DOCUMENT

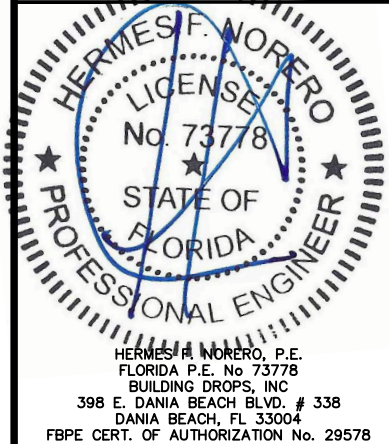

FL #:
FL21060

DATE: **09.06.17**

DWG. BY: **CL** CHK. BY: **HFN**

SCALE: **NTS**

DWG. #: **JW063**

SHEET:

s:\projects\jeld-wen\fb-c-19-0536 - fbc submittal - product name update, w-5500, fl17868, fl21060, fl26356.dwg\jw063.dwg 6/14/2019 2:40 PM

Maximum design pressure capacity chart (psf):

L - Mull Length (in)	W - Tributary Width (in)														
	18.0	24.0	30.0	36.0	39.0	42.0	45.0	48.0	51.0	54.0	57.0	60.0	63.0	66.0	72.0
24.0	65.0	65.0	65.0	65.0	65.0	65.0	65.0	65.0	65.0	65.0	65.0	65.0	65.0	65.0	65.0
30.0	65.0	65.0	65.0	65.0	65.0	65.0	65.0	65.0	65.0	65.0	65.0	65.0	65.0	65.0	65.0
36.0	65.0	65.0	65.0	65.0	65.0	65.0	65.0	65.0	65.0	65.0	65.0	65.0	65.0	65.0	65.0
42.0	65.0	65.0	65.0	65.0	65.0	65.0	65.0	65.0	65.0	65.0	65.0	65.0	65.0	65.0	61.2
48.0	65.0	65.0	65.0	65.0	65.0	65.0	65.0	65.0	65.0	62.5	59.2	56.3	53.6	51.1	46.9
54.0	65.0	65.0	65.0	65.0	65.0	63.5	59.3	55.6	52.3	49.4	46.8	44.4	42.3	40.4	37.0
60.0	65.0	65.0	65.0	60.0	55.4	51.4	48.0	45.0	42.4	40.0	37.9	36.0	34.3	32.7	30.0
66.0	65.0	65.0	59.5	49.6	45.8	42.5	39.7	37.2	35.0	33.1	31.3	29.8	28.3	27.0	24.8
72.0	65.0	62.5	50.0	41.7	38.5	35.7	33.3	31.3	29.4	27.8	26.3	25.0	23.8	22.7	20.8
78.0	65.0	53.3	42.6	35.5	32.8	30.4	28.4	26.6	25.1	23.7	22.4	21.3	20.3	19.4	17.8
84.0	61.2	45.9	36.7	30.6	28.3	26.2	24.5	23.0	21.6	20.4	19.3	18.4	17.5	16.7	15.3
90.0	53.3	40.0	32.0	26.7	24.6	22.9	21.3	20.0	18.8	17.8	16.8	16.0	15.2	-	-
96.0	45.2	33.9	27.1	22.6	20.9	19.4	18.1	17.0	16.0	15.1	-	-	-	-	-
102.0	37.7	28.3	22.6	18.8	17.4	16.2	15.1	-	-	-	-	-	-	-	-
108.0	31.7	23.8	19.0	15.9	-	-	-	-	-	-	-	-	-	-	-
114.0	27.0	20.2	16.2	-	-	-	-	-	-	-	-	-	-	-	-
120.0	23.1	17.4	-	-	-	-	-	-	-	-	-	-	-	-	-

Maximum design pressure capacity chart (psf):

L - Mull Length (in)	W - Tributary Width (in)														
	18.0	24.0	30.0	36.0	39.0	42.0	45.0	48.0	51.0	54.0	57.0	60.0	63.0	66.0	72.0
24.0	65.0	65.0	65.0	65.0	65.0	65.0	65.0	65.0	65.0	65.0	65.0	65.0	65.0	65.0	65.0
30.0	65.0	65.0	65.0	65.0	65.0	65.0	65.0	65.0	65.0	65.0	65.0	65.0	65.0	65.0	65.0
36.0	65.0	65.0	65.0	65.0	65.0	65.0	65.0	65.0	65.0	65.0	65.0	65.0	65.0	65.0	65.0
42.0	65.0	65.0	65.0	65.0	65.0	65.0	65.0	65.0	65.0	65.0	65.0	65.0	65.0	65.0	65.0
48.0	65.0	65.0	65.0	65.0	65.0	65.0	65.0	65.0	65.0	65.0	65.0	65.0	65.0	65.0	65.0
54.0	65.0	65.0	65.0	65.0	65.0	65.0	65.0	65.0	65.0	65.0	65.0	65.0	65.0	65.0	65.0
60.0	65.0	65.0	65.0	65.0	65.0	65.0	65.0	65.0	65.0	65.0	65.0	65.0	65.0	65.0	65.0
66.0	65.0	65.0	65.0	65.0	65.0	65.0	64.7	62.9	61.4	60.2	59.3	58.7	58.3	58.2	58.2
72.0	65.0	65.0	65.0	65.0	61.9	59.2	56.9	55.0	53.4	52.1	51.1	50.3	49.7	49.2	48.9
78.0	65.0	65.0	65.0	58.7	55.5	52.9	50.7	48.9	47.3	46.0	44.9	44.0	43.3	42.7	41.9
84.0	65.0	65.0	61.2	53.3	50.4	47.9	45.8	44.0	42.5	41.2	40.1	39.1	38.3	37.6	36.7
90.0	65.0	65.0	56.3	48.9	46.1	43.7	41.7	40.0	38.5	37.2	36.1	35.2	34.4	33.7	32.6
96.0	65.0	62.9	52.1	45.1	42.5	40.2	38.3	36.7	35.2	34.0	32.9	32.0	31.2	30.5	29.3
102.0	65.0	58.7	48.6	41.9	39.4	37.2	35.4	33.8	32.5	31.3	30.2	29.3	28.5	27.8	26.7
108.0	65.0	55.0	45.4	39.1	36.7	34.7	32.9	31.4	30.1	29.0	28.0	27.1	26.3	25.6	24.4
114.0	65.0	51.8	42.7	36.7	34.4	32.4	30.8	29.3	28.1	27.0	26.0	25.1	24.4	23.7	22.6
120.0	63.4	48.9	40.2	34.5	32.3	30.5	28.9	27.5	26.3	25.2	24.3	23.5	22.7	22.1	21.0



1" SPREAD MULLION

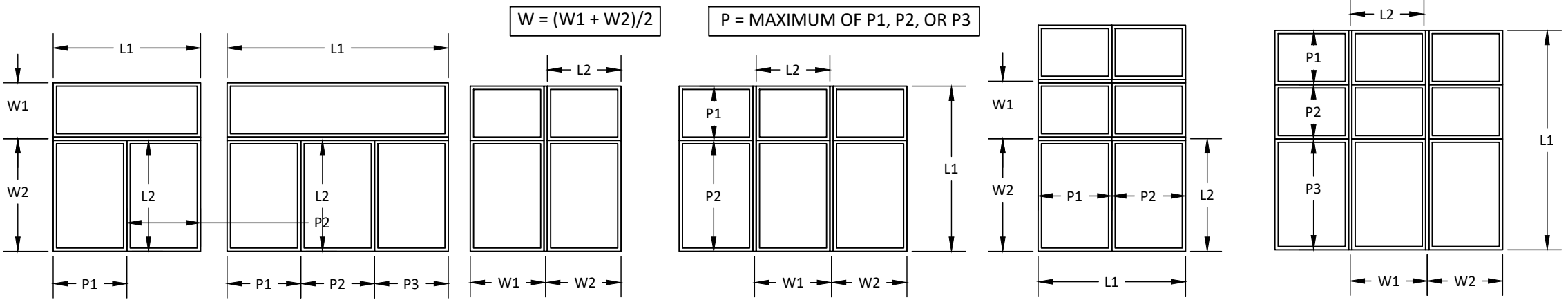

TABLE B.2: TWO WAY MULLIONS 1" SPREAD MULLION CONTINUOUS

1. 'TWO-WAY' MULLIONS REFER TO EITHER 'X' OR 'T' TYPE ASSEMBLIES FOR CONFIGURATIONS DIAGRAMMED ON THIS SHEET.
2. THE DESIGN PRESSURE TABLE HEREIN APPLIES TO MULLION MEMBERS ON SHEET 3 ONLY.
3. WINDOW ASSEMBLIES MAY BE INTERMIXED COMBINATIONS OF FRAMES & MULLIONS AS SHOWN ON SHEETS 2-5.
4. DESIGN PRESSURES LISTED SHALL BE READ AS POSITIVE AND NEGATIVE PRESSURES.
5. DESIGN PRESSURES SHALL BE GOVERNED BY THE LESSER OF THE MULLION ASSEMBLY (LISTED IN TABLE) OR INDIVIDUAL WINDOW UNIT.
6. INDIVIDUAL WINDOW UNITS SHALL BE UNDER SEPARATE APPROVAL.

TABLE B.3: DISCONTINUOUS MULLION

1. THE DESIGN PRESSURE TABLE HEREIN IS LIMITED BY CAPACITY OF MULL JOINT AT 'T' OR 'X' INTERSECTIONS.
2. WINDOW ASSEMBLIES MAY BE INTERMIXED COMBINATIONS OF FRAMES & MULLIONS AS SHOWN ON SHEETS 2-5.
3. DESIGN PRESSURES LISTED SHALL BE READ AS POSITIVE AND NEGATIVE PRESSURES.
4. DESIGN PRESSURES SHALL BE GOVERNED BY THE LESSER OF THE MULLION ASSEMBLY (LISTED IN TABLE) OR INDIVIDUAL WINDOW UNIT.
5. INDIVIDUAL WINDOW UNITS SHALL BE UNDER SEPARATE APPROVAL.

INSTRUCTION NOTE:

1. L1 IS SPAN FOR CONTINUOUS MULLION ASSEMBLY
2. W1 & W2 ARE TRIBUTARY WIDTHS FOR CONTINUOUS MULLION.
3. L2 IS SPAN FOR DISCONTINUOUS MULLION.
4. P1 & P2 ARE TRIBUTARY WIDTHS FOR DISCONTINUOUS MULLION. TAKE MAXIMUM PANEL WIDTH, 'P'.
5. THE LESSER OF TABLE B.2, B.3, AND THE ASSOCIATED 'ONE-WAY' MULL TABLE (TABLE #.1), SHALL GOVERN THE MULL ASSEMBLY DESIGN PRESSURE



3737 LAKEPORT BLVD
KLAMATH FALLS, OR 97601
PH: (541) 882-3451 FAX: (541) 850-2609

TITLE: **SITELINE OR W-5500 WOOD DOUBLE HUNG MULLION TWO WAY "1/4" STRUCTURAL MULLION"**

PREPARED BY: **BUILDING DROPS, INC.**
398 E. DANIA BEACH BLVD., STE. 338
DANIA BEACH, FL 33004
PH: (954) 959-8478
FAX: (954) 744-4738
WEB: www.buildingdrops.com

REMARKS	BY	DATE
6TH FBC CODE CHANGE	CL	9.6.17
W-5500 WOOD ADDITION	LL	6.11.19

THE INSTALLATION DETAILS DESCRIBED HEREIN ARE GENERIC AND MAY NOT REFLECT ACTUAL CONDITIONS FOR A SPECIFIC SITE. IF SITE CONDITIONS CAUSE INSTALLATION TO DEVIATE FROM THE REQUIREMENTS DETAILED HEREIN, A LICENSED ENGINEER OR ARCHITECT SHALL PREPARE SITE SPECIFIC DOCUMENTS FOR USE WITH THIS DOCUMENT

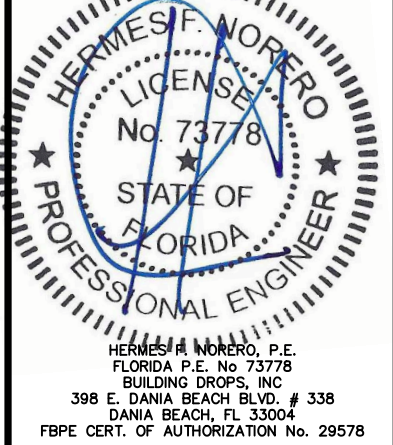

FL #: **FL21060**

DATE: **09.06.17**

DWG. BY: **CL** CHK. BY: **HFN**

SCALE: **NTS**

DWG. #: **JW063**

SHEET: **9**

OF 13

s:\projects\jeld-wen\fb-19-0536 - fbc submittal - product name update, w-5500, fl17868, fl21060, fl26356.dwg, jw063.dwg 6/14/2019 2:40 PM

Maximum design pressure capacity chart (psf):

L - Mull Length (in)	W - Tributary Width (in)														
	18.0	24.0	30.0	36.0	39.0	42.0	45.0	48.0	51.0	54.0	57.0	60.0	63.0	66.0	72.0
24.0	65.0	65.0	65.0	65.0	65.0	65.0	65.0	65.0	65.0	65.0	65.0	65.0	65.0	65.0	65.0
30.0	65.0	65.0	65.0	65.0	65.0	65.0	65.0	65.0	65.0	65.0	65.0	65.0	65.0	65.0	65.0
36.0	65.0	65.0	65.0	65.0	65.0	65.0	65.0	65.0	65.0	65.0	65.0	65.0	65.0	65.0	65.0
42.0	65.0	65.0	65.0	65.0	65.0	65.0	65.0	65.0	65.0	65.0	65.0	65.0	65.0	65.0	65.0
48.0	65.0	65.0	65.0	65.0	65.0	65.0	65.0	65.0	65.0	65.0	65.0	65.0	65.0	65.0	65.0
54.0	65.0	65.0	65.0	65.0	65.0	65.0	65.0	65.0	65.0	65.0	65.0	65.0	65.0	65.0	65.0
60.0	65.0	65.0	65.0	65.0	65.0	65.0	65.0	65.0	65.0	65.0	65.0	65.0	65.0	65.0	65.0
66.0	65.0	65.0	65.0	65.0	65.0	65.0	65.0	65.0	65.0	65.0	65.0	65.0	65.0	65.0	65.0
72.0	65.0	65.0	65.0	65.0	65.0	65.0	65.0	65.0	65.0	65.0	65.0	65.0	65.0	65.0	65.0
78.0	65.0	65.0	65.0	65.0	65.0	65.0	65.0	65.0	65.0	65.0	65.0	65.0	65.0	65.0	64.6
84.0	65.0	65.0	65.0	65.0	65.0	65.0	65.0	65.0	65.0	63.5	61.8	60.3	59.1	58.1	56.6
90.0	65.0	65.0	65.0	65.0	65.0	65.0	64.3	61.7	59.4	57.4	55.8	54.3	53.0	52.0	50.3
96.0	65.0	65.0	65.0	65.0	65.0	62.0	59.1	56.6	54.4	52.5	50.8	49.4	48.1	47.0	45.2
102.0	65.0	65.0	65.0	64.6	60.7	57.4	54.6	52.2	50.1	48.3	46.6	45.0	43.5	42.2	39.9
108.0	65.0	65.0	65.0	57.3	53.4	50.0	47.1	44.6	42.4	40.5	38.8	37.3	36.0	34.9	33.0
114.0	65.0	65.0	57.5	48.5	45.1	42.2	39.7	37.6	35.7	34.1	32.6	31.3	30.2	29.2	27.5
120.0	65.0	60.9	49.2	41.4	38.5	36.0	33.8	32.0	30.4	28.9	27.7	26.6	25.6	24.7	23.2

TABLE C.1: ONE WAY MULLIONS 2" SOLID SPREAD MULLION

1. "ONE-WAY" MULLIONS REFER TO EITHER VERTICAL RIBBON OR HORIZONTAL STACKED ASSEMBLIES SIMILAR TO THOSE DIAGRAMMED ON THIS SHEET.
2. THE DESIGN PRESSURE TABLE HEREIN APPLIES TO MULLION MEMBERS ON SHEET 4 ONLY.
3. WINDOW ASSEMBLIES MAY BE INTERMIXED COMBINATIONS OF FRAMES & MULLIONS AS SHOWN ON SHEETS 2-5.
4. DESIGN PRESSURES LISTED SHALL BE READ AS POSITIVE AND NEGATIVE PRESSURES.
5. DESIGN PRESSURES SHALL BE GOVERNED BY THE LESSER OF THE MULLION ASSEMBLY (LISTED IN TABLE) OR INDIVIDUAL WINDOW UNIT.
6. INDIVIDUAL WINDOW UNITS SHALL BE UNDER SEPARATE APPROVAL.



2" SPREAD MULLION

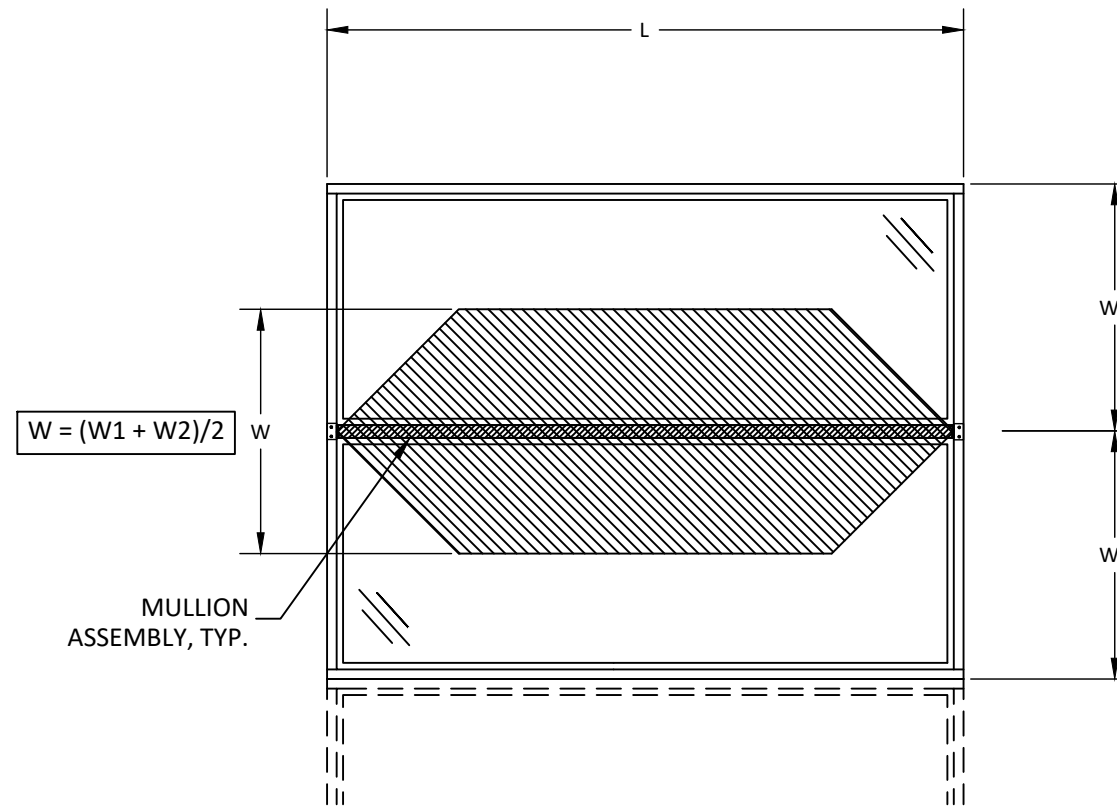
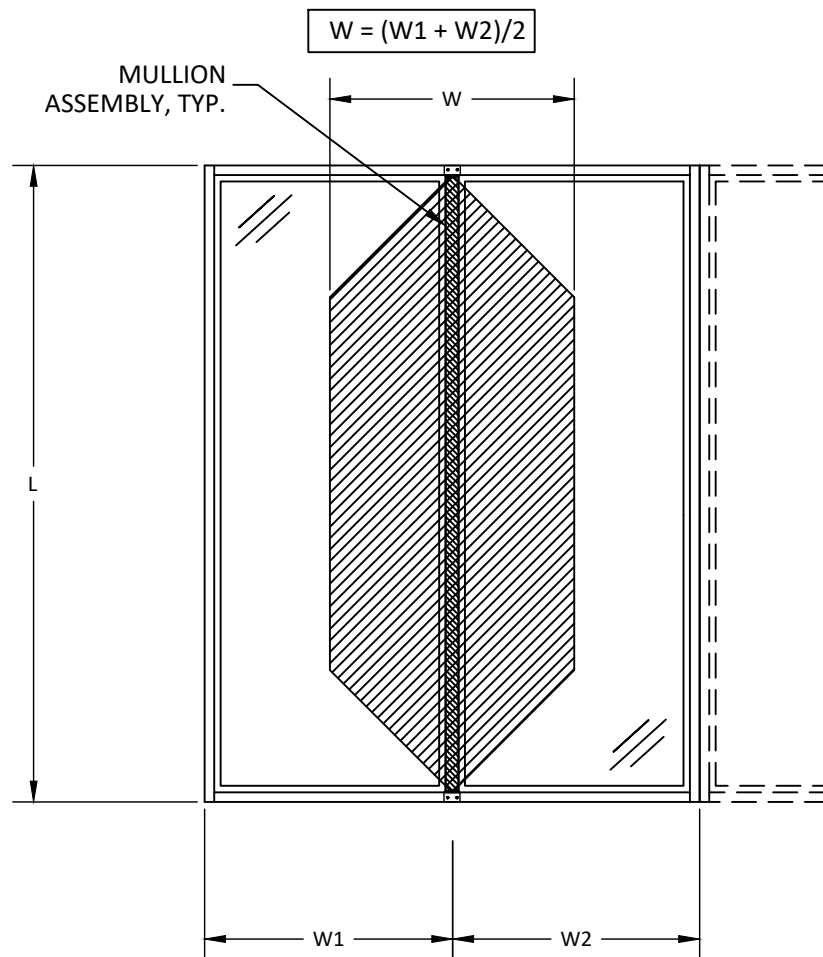

3737 LAKEPORT BLVD
KLAMATH FALLS, OR 97601
PH: (541) 882-3451 FAX: (541) 850-2609

TITLE:
SITELINE OR W-5500 WOOD DOUBLE HUNG MULLION
ONE WAY "3/4" SOLID SPREAD MULLION"

PREPARED BY:
BUILDING DROPS, INC.
398 E. DANIA BEACH BLVD., STE. 338
DANIA BEACH, FL 33004
PH: (954) 999-8478
FAX: (954) 744-4738
WEB: www.buildingdrops.com

REMARKS	BY	DATE
6TH FBC CODE CHANGE	CL	9.6.17
W-5500 WOOD ADDITION	LL	6.11.19

THE INSTALLATION DETAILS DESCRIBED HEREIN ARE GENERIC AND MAY NOT REFLECT ACTUAL CONDITIONS FOR A SPECIFIC SITE. IF SITE CONDITIONS CAUSE INSTALLATION TO DEVIATE FROM THE REQUIREMENTS DETAILED HEREIN, A LICENSED ENGINEER OR ARCHITECT SHALL PREPARE SITE SPECIFIC DOCUMENTS FOR USE WITH THIS DOCUMENT

HERMES F. NORERO, P.E.
FLORIDA P.E. No. 73778
BUILDING DROPS, INC
398 E. DANIA BEACH BLVD. # 338
DANIA BEACH, FL 33004
FBPE CERT. OF AUTHORIZATION No. 29578

FL #:
FL21060

DATE: **09.06.17**

DWG. BY: **CL** | CHK. BY: **HFN**

SCALE: **NTS**

DWG. #: **JW063**

SHEET:
10
OF 13

s:\projects\jeld-wen\fb-c-19-0536 - fbc submittal - product name update, w-5500, fl21060, fl20361.dwg, jw063.dwg 6/14/2019 2:40 PM

Maximum design pressure capacity chart (psf):

L - Mull Length (in)	W - Tributary Width (in)														
	18.0	24.0	30.0	36.0	39.0	42.0	45.0	48.0	51.0	54.0	57.0	60.0	63.0	66.0	72.0
24.0	65.0	65.0	65.0	65.0	65.0	65.0	65.0	65.0	65.0	65.0	65.0	65.0	65.0	65.0	65.0
30.0	65.0	65.0	65.0	65.0	65.0	65.0	65.0	65.0	65.0	65.0	65.0	65.0	65.0	65.0	65.0
36.0	65.0	65.0	65.0	65.0	65.0	65.0	65.0	65.0	65.0	65.0	65.0	65.0	65.0	65.0	65.0
42.0	65.0	65.0	65.0	65.0	65.0	65.0	65.0	65.0	65.0	65.0	65.0	65.0	65.0	65.0	65.0
48.0	65.0	65.0	65.0	65.0	65.0	65.0	65.0	65.0	65.0	65.0	65.0	65.0	65.0	62.7	57.5
54.0	65.0	65.0	65.0	65.0	65.0	65.0	65.0	65.0	65.0	65.0	65.0	64.6	61.3	58.4	51.1
60.0	65.0	65.0	65.0	65.0	65.0	65.0	65.0	65.0	65.0	64.9	61.3	58.1	55.2	52.6	46.0
66.0	65.0	65.0	65.0	65.0	65.0	65.0	65.0	65.0	62.7	59.0	55.8	52.8	50.2	47.8	41.8
72.0	65.0	65.0	65.0	65.0	65.0	65.0	65.0	61.3	57.5	54.1	51.1	48.4	46.0	43.8	38.3
78.0	65.0	65.0	65.0	65.0	65.0	60.7	56.6	53.1	50.0	47.2	44.7	42.5	40.4	38.6	35.4
84.0	65.0	65.0	65.0	61.2	56.5	52.5	49.0	45.9	43.2	40.8	38.7	36.7	35.0	33.4	30.6
90.0	65.0	65.0	64.0	53.3	49.2	45.7	42.7	40.0	37.6	35.6	33.7	32.0	30.5	29.1	26.7
96.0	65.0	65.0	54.2	45.2	41.7	38.7	36.2	33.9	31.9	30.1	28.5	27.1	25.8	24.7	22.6
102.0	65.0	56.5	45.2	37.7	34.8	32.3	30.1	28.3	26.6	25.1	23.8	22.6	21.5	20.6	18.8
108.0	63.5	47.6	38.1	31.7	29.3	27.2	25.4	23.8	22.4	21.2	20.1	19.0	18.1	17.3	15.9
114.0	54.0	40.5	32.4	27.0	24.9	23.1	21.6	20.2	19.1	18.0	17.0	16.2	15.4	-	-
120.0	46.3	34.7	27.8	23.1	21.4	19.8	18.5	17.4	16.3	15.4	-	-	-	-	-

Maximum design pressure capacity chart (psf):

L - Mull Length (in)	W - Tributary Width (in)														
	18.0	24.0	30.0	36.0	39.0	42.0	45.0	48.0	51.0	54.0	57.0	60.0	63.0	66.0	72.0
24.0	65.0	65.0	65.0	65.0	65.0	65.0	65.0	65.0	65.0	65.0	65.0	65.0	65.0	65.0	65.0
30.0	65.0	65.0	65.0	65.0	65.0	65.0	65.0	65.0	65.0	65.0	65.0	65.0	65.0	65.0	65.0
36.0	65.0	65.0	65.0	65.0	65.0	65.0	65.0	65.0	65.0	65.0	65.0	65.0	65.0	65.0	65.0
42.0	65.0	65.0	65.0	65.0	65.0	65.0	65.0	65.0	65.0	65.0	65.0	65.0	65.0	65.0	65.0
48.0	65.0	65.0	65.0	65.0	65.0	65.0	65.0	65.0	65.0	65.0	65.0	65.0	65.0	65.0	65.0
54.0	65.0	65.0	65.0	65.0	65.0	65.0	65.0	65.0	65.0	65.0	65.0	65.0	65.0	65.0	65.0
60.0	65.0	65.0	65.0	65.0	65.0	65.0	65.0	65.0	65.0	65.0	65.0	65.0	65.0	65.0	65.0
66.0	65.0	65.0	65.0	65.0	65.0	65.0	64.7	62.9	61.4	60.2	59.3	58.7	58.3	58.2	58.2
72.0	65.0	65.0	65.0	65.0	61.9	59.2	56.9	55.0	53.4	52.1	51.1	50.3	49.7	49.2	48.9
78.0	65.0	65.0	65.0	58.7	55.5	52.9	50.7	48.9	47.3	46.0	44.9	44.0	43.3	42.7	41.9
84.0	65.0	65.0	61.2	53.3	50.4	47.9	45.8	44.0	42.5	41.2	40.1	39.1	38.3	37.6	36.7
90.0	65.0	65.0	56.3	48.9	46.1	43.7	41.7	40.0	38.5	37.2	36.1	35.2	34.4	33.7	32.6
96.0	65.0	62.9	52.1	45.1	42.5	40.2	38.3	36.7	35.2	34.0	32.9	32.0	31.2	30.5	29.3
102.0	65.0	58.7	48.6	41.9	39.4	37.2	35.4	33.8	32.5	31.3	30.2	29.3	28.5	27.8	26.7
108.0	65.0	55.0	45.4	39.1	36.7	34.7	32.9	31.4	30.1	29.0	28.0	27.1	26.3	25.6	24.4
114.0	65.0	51.8	42.7	36.7	34.4	32.4	30.8	29.3	28.1	27.0	26.0	25.1	24.4	23.7	22.6
120.0	63.4	48.9	40.2	34.5	32.3	30.5	28.9	27.5	26.3	25.2	24.3	23.5	22.7	22.1	21.0



2" SPREAD MULLION

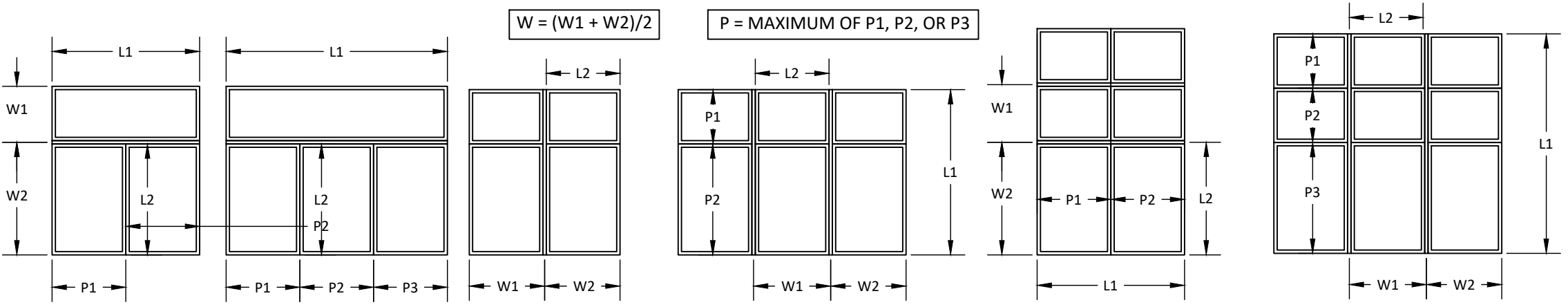

QUALIFIED CONFIGURATIONS

TABLE C.2: TWO WAY MULLIONS 2" SOLID SPREAD MULLION CONTINUOUS

1. 'TW-WAY' MULLIONS REFER TO EITHER 'X' OR 'T' TYPE ASSEMBLIES SIMILAR TO THOSE DIAGRAMMED ON THIS SHEET.
2. THE DESIGN PRESSURE TABLE HEREIN APPLIES TO MULLION MEMBERS ON SHEET 4 ONLY.
3. WINDOW ASSEMBLIES MAY BE INTERMIXED COMBINATIONS OF FRAMES & MULLIONS AS SHOWN ON SHEETS 2-5.
4. DESIGN PRESSURES LISTED SHALL BE READ AS POSITIVE AND NEGATIVE PRESSURES.
5. DESIGN PRESSURES SHALL BE GOVERNED BY THE LESSER OF THE MULLION ASSEMBLY (LISTED IN TABLE) OR INDIVIDUAL WINDOW UNIT.
6. INDIVIDUAL WINDOW UNITS SHALL BE UNDER SEPARATE APPROVAL.

TABLE C.3: DISCONTINUOUS MULLION

1. THE DESIGN PRESSURE TABLE HEREIN IS LIMITED BY CAPACITY OF MULL JOINT AT 'T' OR 'X' INTERSECTIONS.
2. WINDOW ASSEMBLIES MAY BE INTERMIXED COMBINATIONS OF FRAMES & MULLIONS AS SHOWN ON SHEETS 2-5.
3. DESIGN PRESSURES LISTED SHALL BE READ AS POSITIVE AND NEGATIVE PRESSURES.
4. DESIGN PRESSURES SHALL BE GOVERNED BY THE LESSER OF THE MULLION ASSEMBLY (LISTED IN TABLE) OR INDIVIDUAL WINDOW UNIT.
5. INDIVIDUAL WINDOW UNITS SHALL BE UNDER SEPARATE APPROVAL.

INSTRUCTION NOTE:

1. L1 IS SPAN FOR CONTINUOUS MULLION ASSEMBLY
2. W1 & W2 ARE TRIBUTARY WIDTHS FOR CONTINUOUS MULLION.
3. L2 IS SPAN FOR DISCONTINUOUS MULLION.
4. P1 & P2 ARE TRIBUTARY WIDTHS FOR DISCONTINUOUS MULLION. TAKE MAXIMUM PANEL WIDTH, 'P'.
5. THE LESSER OF TABLE C.2, C.3, AND THE ASSOCIATED 'ONE-WAY' MULL TABLE (TABLE #.1), SHALL GOVERN THE MULL ASSEMBLY DESIGN PRESSURE



3737 LAKEPORT BLVD
KLAMATH FALLS, OR 97601
PH: (541) 882-3451 FAX: (541) 850-2609

TITLE:
SITELINE OR W-5500 WOOD DOUBLE HUNG MULLION
TWO WAY "3/4" SOLID SPREAD MULLION"

PREPARED BY:
BUILDING DROPS, INC.
398 E. DANIA BEACH BLVD., STE. 338
DANIA BEACH, FL 33004
PH: (954) 959-8478
FAX: (954) 744-4738
WEB: www.buildingdrops.com



REMARKS	BY	DATE
6TH FBC CODE CHANGE	CL	9.6.17
W-5500 WOOD ADDITION	LL	6.11.19

THE INSTALLATION DETAILS DESCRIBED HEREIN ARE GENERIC AND MAY NOT REFLECT ACTUAL CONDITIONS FOR A SPECIFIC SITE. IF SITE CONDITIONS CAUSE INSTALLATION TO DEVIATE FROM THE REQUIREMENTS DETAILED HEREIN, A LICENSED ENGINEER OR ARCHITECT SHALL PREPARE SITE SPECIFIC DOCUMENTS FOR USE WITH THIS DOCUMENT

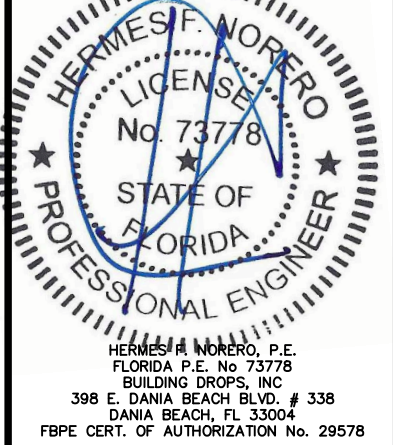

FL #:	FL21060
DATE:	09.06.17
DWG. BY:	CL
CHK. BY:	HFN
SCALE:	NTS
DWG. #:	JW063
SHEET:	11

s:\projects\jeld-wen\fb-c-19-0536 - fbc submittal - product name update, w-5500, fl17868, fl21060, fl26356.dwg, jw063.dwg 6/14/2019 2:40 PM

Maximum design pressure capacity chart (psf):

L - Mull Length (in)	W - Tributary Width (in)														
	18.0	24.0	30.0	36.0	39.0	42.0	45.0	48.0	51.0	54.0	57.0	60.0	63.0	66.0	72.0
24.0	65.0	65.0	65.0	65.0	65.0	65.0	65.0	65.0	65.0	65.0	65.0	65.0	65.0	65.0	65.0
30.0	65.0	65.0	65.0	65.0	65.0	65.0	65.0	65.0	65.0	65.0	65.0	65.0	65.0	65.0	65.0
36.0	65.0	65.0	65.0	65.0	65.0	65.0	65.0	65.0	65.0	65.0	65.0	65.0	65.0	65.0	65.0
42.0	65.0	65.0	65.0	65.0	65.0	65.0	65.0	65.0	65.0	65.0	65.0	65.0	65.0	65.0	65.0
48.0	65.0	65.0	65.0	65.0	65.0	65.0	65.0	65.0	65.0	65.0	65.0	65.0	65.0	65.0	65.0
54.0	65.0	65.0	65.0	65.0	65.0	65.0	65.0	65.0	65.0	65.0	65.0	65.0	65.0	65.0	65.0
60.0	65.0	65.0	65.0	65.0	65.0	65.0	65.0	65.0	65.0	65.0	65.0	65.0	65.0	65.0	65.0
66.0	65.0	65.0	65.0	65.0	65.0	65.0	65.0	65.0	65.0	65.0	65.0	65.0	65.0	65.0	65.0
72.0	65.0	65.0	65.0	65.0	65.0	65.0	65.0	65.0	65.0	65.0	65.0	65.0	65.0	65.0	65.0
78.0	65.0	65.0	65.0	65.0	65.0	65.0	65.0	65.0	65.0	65.0	65.0	65.0	65.0	65.0	65.0
84.0	65.0	65.0	65.0	65.0	65.0	65.0	65.0	65.0	65.0	65.0	64.6	62.8	61.3	60.1	59.0
90.0	65.0	65.0	65.0	65.0	65.0	65.0	65.0	65.0	65.0	65.0	62.7	60.4	58.4	56.7	55.2
96.0	65.0	65.0	65.0	65.0	65.0	65.0	63.1	60.1	57.5	55.3	53.3	51.6	50.2	48.9	47.8
102.0	65.0	65.0	65.0	65.0	65.0	61.8	58.4	55.5	53.1	50.9	49.1	47.4	46.0	44.7	43.6
108.0	65.0	65.0	65.0	61.3	57.6	54.4	51.6	49.3	47.2	45.4	43.9	42.5	41.2	40.1	38.3
114.0	65.0	65.0	65.0	57.5	53.9	50.9	48.3	46.0	44.0	42.3	40.8	39.4	38.2	37.2	35.4
120.0	65.0	65.0	63.1	54.1	50.7	47.8	45.3	43.1	41.2	39.6	38.1	36.8	35.6	34.6	32.9

- TABLE D.1: ONE WAY MULLIONS 4" SOLID SPREAD MULLION**
1. "ONE-WAY" MULLIONS REFER TO EITHER VERTICAL RIBBON OR HORIZONTAL STACKED ASSEMBLIES SIMILAR TO THOSE DIAGRAMMED ON THIS SHEET.
 2. THE DESIGN PRESSURE TABLE HEREIN APPLIES TO MULLION MEMBERS ON SHEET 5 ONLY.
 3. WINDOW ASSEMBLIES MAY BE INTERMIXED COMBINATIONS OF FRAMES & MULLIONS AS SHOWN ON SHEETS 2-5.
 4. DESIGN PRESSURES LISTED SHALL BE READ AS POSITIVE AND NEGATIVE PRESSURES.
 5. DESIGN PRESSURES SHALL BE GOVERNED BY THE LESSER OF THE MULLION ASSEMBLY (LISTED IN TABLE) OR INDIVIDUAL WINDOW UNIT.
 6. INDIVIDUAL WINDOW UNITS SHALL BE UNDER SEPARATE APPROVAL.

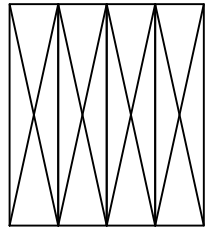

4" SPREAD MULLION

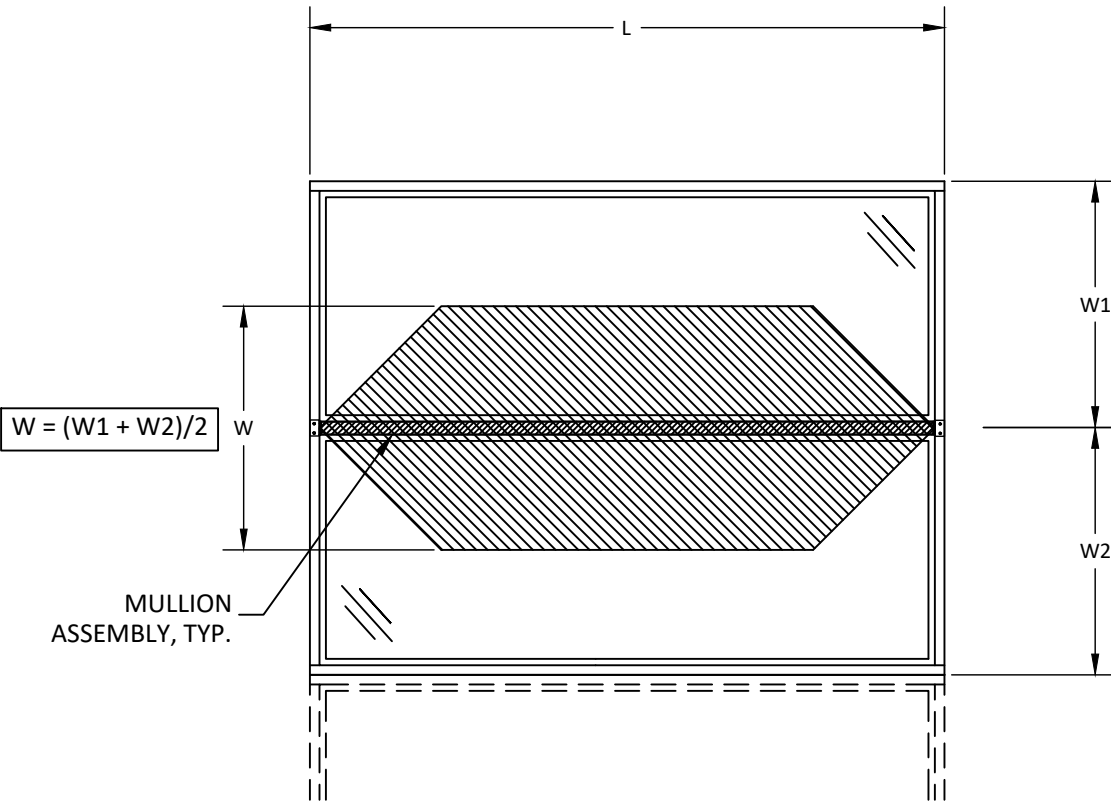
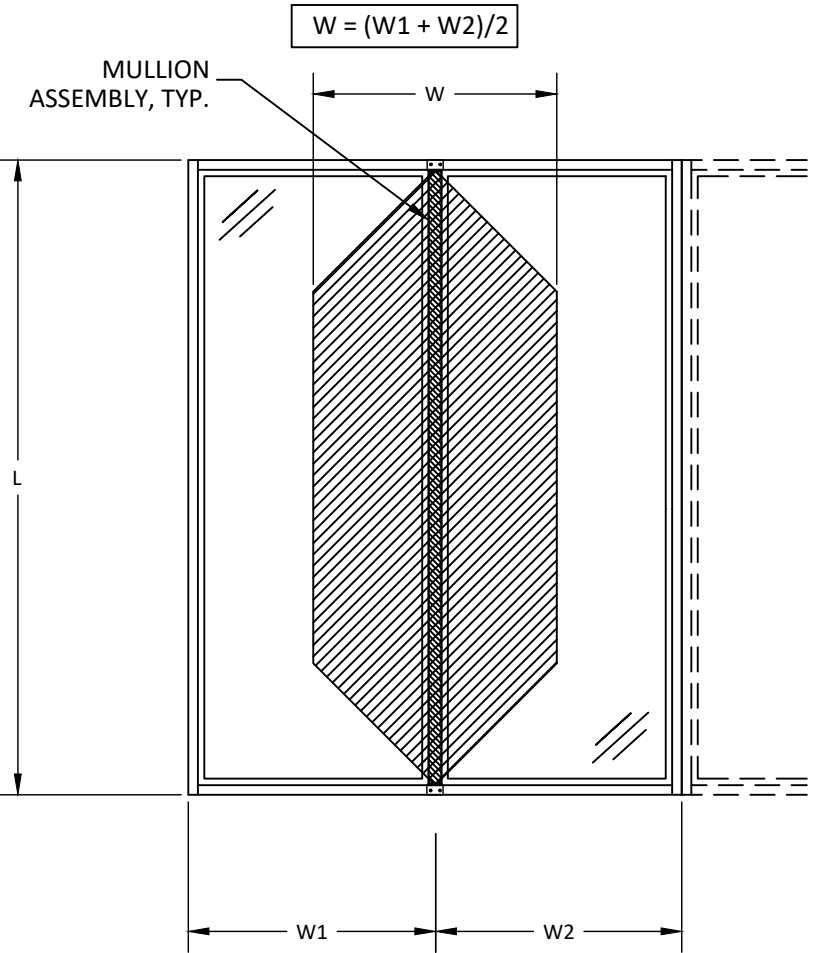

3737 LAKEPORT BLVD
KLAMATH FALLS, OR 97601
PH: (541) 882-3451 FAX: (541) 850-2609

TITLE:
SITELINE OR W-5500 WOOD DOUBLE HUNG MULLION
ONE WAY "1" SOLID SPREAD MULLION"

PREPARED BY:
BUILDING DROPS, INC.
398 E. DANIA BEACH BLVD., STE. 338
DANIA BEACH, FL 33004
PH: (954) 999-8478
FAX: (954) 744-4738
WEB: www.buildingdrops.com



REMARKS	BY	DATE
6TH FBC CODE CHANGE	CL	9.6.17
W-5500 WOOD ADDITION	LL	6.11.19

THE INSTALLATION DETAILS DESCRIBED HEREIN ARE GENERIC AND MAY NOT REFLECT ACTUAL CONDITIONS FOR A SPECIFIC SITE. IF SITE CONDITIONS CAUSE INSTALLATION TO DEVIATE FROM THE REQUIREMENTS DETAILED HEREIN, A LICENSED ENGINEER OR ARCHITECT SHALL PREPARE SITE SPECIFIC DOCUMENTS FOR USE WITH THIS DOCUMENT

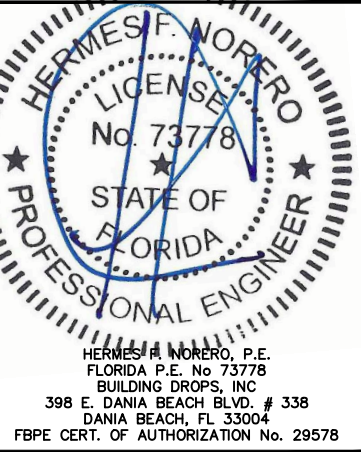

FL #:
FL21060

DATE: **09.06.17**

DWG. BY: **CL** | CHK. BY: **HFN**

SCALE: **NTS**

DWG. #: **JW063**

SHEET:

s:\projects\jeld-wen\fb-c-19-0536 - fbc submittal - product name update, w-5500, fl21060, fl20356.dwg, jw063.dwg 6/14/2019 2:40 PM

Maximum design pressure capacity chart (psf):

L - Mull Length (in)	W - Tributary Width (in)														
	18.0	24.0	30.0	36.0	39.0	42.0	45.0	48.0	51.0	54.0	57.0	60.0	63.0	66.0	72.0
24.0	65.0	65.0	65.0	65.0	65.0	65.0	65.0	65.0	65.0	65.0	65.0	65.0	65.0	65.0	65.0
30.0	65.0	65.0	65.0	65.0	65.0	65.0	65.0	65.0	65.0	65.0	65.0	65.0	65.0	65.0	65.0
36.0	65.0	65.0	65.0	65.0	65.0	65.0	65.0	65.0	65.0	65.0	65.0	65.0	65.0	65.0	65.0
42.0	65.0	65.0	65.0	65.0	65.0	65.0	65.0	65.0	65.0	65.0	65.0	65.0	65.0	65.0	65.0
48.0	65.0	65.0	65.0	65.0	65.0	65.0	65.0	65.0	65.0	65.0	65.0	65.0	65.0	62.7	57.5
54.0	65.0	65.0	65.0	65.0	65.0	65.0	65.0	65.0	65.0	65.0	64.6	61.3	58.4	55.8	51.1
60.0	65.0	65.0	65.0	65.0	65.0	65.0	65.0	65.0	64.9	61.3	58.1	55.2	52.6	50.2	46.0
66.0	65.0	65.0	65.0	65.0	65.0	65.0	65.0	62.7	59.0	55.8	52.8	50.2	47.8	45.6	41.8
72.0	65.0	65.0	65.0	65.0	65.0	65.0	61.3	57.5	54.1	51.1	48.4	46.0	43.8	41.8	38.3
78.0	65.0	65.0	65.0	65.0	65.0	60.7	56.6	53.1	50.0	47.2	44.7	42.5	40.4	38.6	35.4
84.0	65.0	65.0	65.0	65.0	60.7	56.3	52.6	49.3	46.4	43.8	41.5	39.4	37.6	35.8	32.9
90.0	65.0	65.0	65.0	61.3	56.6	52.6	49.1	46.0	43.3	40.9	38.7	36.8	35.0	33.5	30.7
96.0	65.0	65.0	65.0	57.5	53.1	49.3	46.0	43.1	40.6	38.3	36.3	34.5	32.9	31.4	28.8
102.0	65.0	65.0	64.9	54.1	50.0	46.4	43.3	40.6	38.2	36.1	34.2	32.5	30.9	29.5	27.1
108.0	65.0	65.0	61.3	51.1	47.2	43.8	40.9	38.3	36.1	34.1	32.3	30.7	29.2	27.9	25.6
114.0	65.0	65.0	58.1	48.4	44.7	41.5	38.7	36.3	34.2	32.3	30.6	29.1	27.7	26.4	24.2
120.0	65.0	65.0	55.2	46.0	42.5	39.4	36.8	34.5	32.5	30.7	29.1	27.6	26.3	25.1	23.0

Maximum design pressure capacity chart (psf):

L - Mull Length (in)	W - Tributary Width (in)														
	18.0	24.0	30.0	36.0	39.0	42.0	45.0	48.0	51.0	54.0	57.0	60.0	63.0	66.0	72.0
24.0	65.0	65.0	65.0	65.0	65.0	65.0	65.0	65.0	65.0	65.0	65.0	65.0	65.0	65.0	65.0
30.0	65.0	65.0	65.0	65.0	65.0	65.0	65.0	65.0	65.0	65.0	65.0	65.0	65.0	65.0	65.0
36.0	65.0	65.0	65.0	65.0	65.0	65.0	65.0	65.0	65.0	65.0	65.0	65.0	65.0	65.0	65.0
42.0	65.0	65.0	65.0	65.0	65.0	65.0	65.0	65.0	65.0	65.0	65.0	65.0	65.0	65.0	65.0
48.0	65.0	65.0	65.0	65.0	65.0	65.0	65.0	65.0	65.0	65.0	65.0	65.0	65.0	65.0	65.0
54.0	65.0	65.0	65.0	65.0	65.0	65.0	65.0	65.0	65.0	65.0	65.0	65.0	65.0	65.0	65.0
60.0	65.0	65.0	65.0	65.0	65.0	65.0	65.0	65.0	65.0	65.0	65.0	65.0	65.0	65.0	65.0
66.0	65.0	65.0	65.0	65.0	65.0	65.0	64.7	62.9	61.4	60.2	59.3	58.7	58.3	58.2	58.2
72.0	65.0	65.0	65.0	65.0	61.9	59.2	56.9	55.0	53.4	52.1	51.1	50.3	49.7	49.2	48.9
78.0	65.0	65.0	65.0	58.7	55.5	52.9	50.7	48.9	47.3	46.0	44.9	44.0	43.3	42.7	41.9
84.0	65.0	65.0	61.2	53.3	50.4	47.9	45.8	44.0	42.5	41.2	40.1	39.1	38.3	37.6	36.7
90.0	65.0	65.0	56.3	48.9	46.1	43.7	41.7	40.0	38.5	37.2	36.1	35.2	34.4	33.7	32.6
96.0	65.0	62.9	52.1	45.1	42.5	40.2	38.3	36.7	35.2	34.0	32.9	32.0	31.2	30.5	29.3
102.0	65.0	58.7	48.6	41.9	39.4	37.2	35.4	33.8	32.5	31.3	30.2	29.3	28.5	27.8	26.7
108.0	65.0	55.0	45.4	39.1	36.7	34.7	32.9	31.4	30.1	29.0	28.0	27.1	26.3	25.6	24.4
114.0	65.0	51.8	42.7	36.7	34.4	32.4	30.8	29.3	28.1	27.0	26.0	25.1	24.4	23.7	22.6
120.0	63.4	48.9	40.2	34.5	32.3	30.5	28.9	27.5	26.3	25.2	24.3	23.5	22.7	22.1	21.0

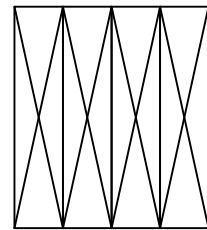

4" SPREAD MULLION

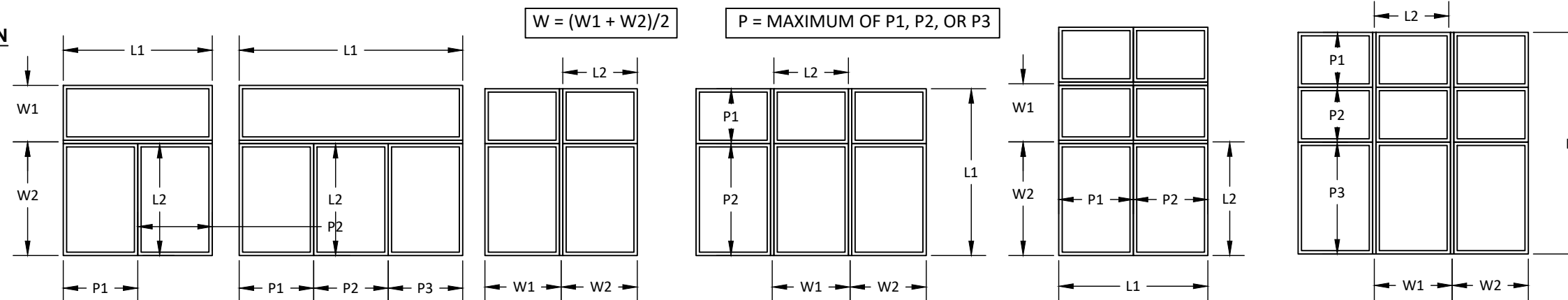

QUALIFIED CONFIGURATIONS

TABLE D.2: TWO WAY MULLIONS 4" SOLID SPREAD MULLION CONTINUOUS

1. 'TWO-WAY' MULLIONS REFER TO EITHER 'X' OR 'T' TYPE ASSEMBLIES SIMILAR TO THOSE DIAGRAMMED ON THIS SHEET.
2. THE DESIGN PRESSURE TABLE HEREIN APPLIES TO MULLION MEMBERS ON SHEETS 5 ONLY.
3. WINDOW ASSEMBLIES MAY BE INTERMIXED COMBINATIONS OF FRAMES & MULLIONS AS SHOWN ON SHEETS 2-5.
4. DESIGN PRESSURES LISTED ABOVE SHALL BE READ AS POSITIVE AND NEGATIVE PRESSURES.
5. DESIGN PRESSURES SHALL BE GOVERNED BY THE LESSER OF THE MULLION ASSEMBLY (LISTED IN TABLE) OR INDIVIDUAL WINDOW UNIT.
6. INDIVIDUAL WINDOW UNITS SHALL BE UNDER SEPARATE APPROVAL.

TABLE D.3: DISCONTINUOUS MULLION

1. THE DESIGN PRESSURE TABLE HEREIN IS LIMITED BY CAPACITY OF MULL JOINT AT 'T' OR 'X' INTERSECTIONS.
2. WINDOW ASSEMBLIES MAY BE INTERMIXED COMBINATIONS OF FRAMES & MULLIONS AS SHOWN ON SHEETS 2-5.
3. DESIGN PRESSURES LISTED SHALL BE READ AS POSITIVE AND NEGATIVE PRESSURES.
4. DESIGN PRESSURES SHALL BE GOVERNED BY THE LESSER OF THE MULLION ASSEMBLY (LISTED IN TABLE) OR INDIVIDUAL WINDOW UNIT.
5. INDIVIDUAL WINDOW UNITS SHALL BE UNDER SEPARATE APPROVAL.

INSTRUCTION NOTE:

1. L1 IS SPAN FOR CONTINUOUS MULLION ASSEMBLY
2. W1 & W2 ARE TRIBUTARY WIDTHS FOR CONTINUOUS MULLION.
3. L2 IS SPAN FOR DISCONTINUOUS MULLION.
4. P1 & P2 ARE TRIBUTARY WIDTHS FOR DISCONTINUOUS MULLION. TAKE MAXIMUM PANEL WIDTH, 'P'.
5. THE LESSER OF TABLE D.2, D.3, AND THE ASSOCIATED 'ONE-WAY' MULL TABLE (TABLE #.1), SHALL GOVERN THE MULL ASSEMBLY DESIGN PRESSURE



3737 LAKEPORT BLVD
KLAMATH FALLS, OR 97601
PH: (541) 882-3451 FAX: (541) 850-2609

TITLE: SITELINE OR W-5500 WOOD DOUBLE HUNG MULLION TWO WAY "I" SOLID SPREAD MULLION

PREPARED BY: BUILDING DROPS, INC.
398 E. DANIA BEACH BLVD., STE. 338
DANIA BEACH, FL 33004
PH: (954) 999-8478
FAX: (954) 744-4738
WEB: www.buildingdrops.com

REMARKS	BY	DATE
6TH FBC CODE CHANGE	CL	9.6.17
W-5500 WOOD ADDITION	LL	6.11.19

THE INSTALLATION DETAILS DESCRIBED HEREIN ARE GENERIC AND MAY NOT REFLECT ACTUAL CONDITIONS FOR A SPECIFIC SITE. IF SITE CONDITIONS CAUSE INSTALLATION TO DEVIATE FROM THE REQUIREMENTS DETAILED HEREIN, A LICENSED ENGINEER OR ARCHITECT SHALL PREPARE SITE SPECIFIC DOCUMENTS FOR USE WITH THIS DOCUMENT

HERMES F. NORERO, P.E.
FLORIDA P.E. No. 73778
BUILDING DROPS, INC.
398 E. DANIA BEACH BLVD. # 338
DANIA BEACH, FL 33004
FBPE CERT. OF AUTHORIZATION No. 29578

FL #: **FL21060**

DATE: **09.06.17**

DWG. BY: **CL** CHK. BY: **HFN**

SCALE: **NTS**

DWG. #: **JW063**

SHEET: **13** OF 13